

CONTENTS

X-RAY RADIATION PRECAUTION.....	1
SAFETY PRECAUTION.....	1
PRODUCT SAFETY NOTICE.....	2
INSTALLATION AND SERVICE ADJUSTMENTS.....	3
GENERAL INSTRUCTION.....	4
ALIGNMENT ITEMS AND PROCEDURE.....	4
FACTORY ADJUSTMENT MODE.....	5
CHECKING POINT.....	6
PRESET THE FOLLOWING IN FACTORY.....	7
FACTORY MENU.....	7
CONVERGENCE MAGNET ASSEMBLY POSITIONING.....	11
COLOR PURITY ADJUSTMENT.....	11
CONVERGENCE ADJUSTMENT.....	12
CENTER CONVERGENCE ADJUSTMENT	12
CIRCUMFERENCE CONVERGENCE ADJUSTMENT	12
USA CHANNEL FREQUENCY TABLE (181 CH).....	14
WIRING DIAGRAM.....	16
BLOCK DIAGRAM.....	17
IC BLOCK DIAGRAM.....	18
COMPONENT AND BOTTOM VIEW.....	26
SCHEMATIC DIAGRAM.....	29
ELECTRICAL PARTS LIST.....	30

CAUTION: THIS SERVICE MANUAL IS ONLY FOR PROFESSIONAL SERVICE PERSONNEL'S REFERENCE. BEFORE SERVICING THIS CHASSIS, PLEASE READ THE FOLLOWING NOTICE ITEMS.

SAFETY INSTRUCTION

Before servicing and aligning this equipment, please read the following “**X-RAY RADIATION PRECAUTION**”, “**SAFETY PRECAUTION**” and “**PRODUCT SAFETY NOTICE**”.

X-RAY RADIATION PRECAUTION

- 1) Excessive high voltage can produce potentially hazardous X-RAY RADIATION. To avoid such hazards, the high voltage must not be above the specified limit. The normal value of the high voltage of this receiver is 29 or 26.5kV(20”) at zero beam current (minimum brightness) under 120V AC power source. the high voltage must not, under any circumstances, exceed 32kV.
- 2) Each time a receiver requires servicing, the high voltage should be checked following the HIGH VOLTAGE CHECK procedure in this manual. It is recommended the reading of the high voltage be recorded as a part of service record. It is important to use an accurate and reliable high voltage meter.
- 3) This receiver is equipped with a Fail Safe (FS) circuit which prevents the receiver from producing an excessively high voltage even if the B+ voltage increases abnormally. Each time the receiver is serviced, the FS circuit must be checked to determine that the circuit is properly functioning, following the FS CIRCUIT CHECK procedure in this manual.
- 4) The primary source of X-RAY RADIATION in this TV receiver is the picture tube. For continuous X-RAY RADIATION protection, the replacement tube must be exactly the same type tube as specified in the parts list.
- 5) Some parts in this receiver have special safety-related characteristics for X-RAY RADIATION protection. For continuous safety, parts replacement should be undertaken only after referring to the PRODUCT SAFETY NOTICE below.

SAFETY PRECAUTION

WARNING:

Service should not be attempted by anyone unfamiliar with the necessary precaution on this receiver. The following are the necessary precautions to be observed before servicing this chassis.

- 1) Since the power supply circuit of this receiver is directly connected to the AC power line, an isolation transformer should be used during any dynamic service to avoid possible shock hazard.
- 2) Always discharge the picture tube anode to the CRT conductive coating before handling the picture tube. The picture tube is highly evacuated and if broken, glass fragments will be violently expelled. Use shatter proof goggles and keep picture tube away from the unprotected body while handling.
- 3) When replacing a chassis in the cabinet, always be certain that all the protective devices are put back in place, such as: non-metallic control knobs, insulating covers, shields, isolation resistor-capacitor network etc.
- 4) When replacing parts or circuit boards, disconnect the power cord.
- 5) When replacing a high wattage resistor (oxide metal film resistor) on the circuit board, keep the resistor 10mm (1/2in) away from circuit board.
- 6) Connection wires must be kept away from components with high voltage or high temperature.
- 7) If any fuse in this TV receiver is blown, replace it with the FUSE specified in the chassis parts list.

- 8) Before returning the set to your customer, always perform an AC leakage current check on the exposed metallic parts of the cabinet, such as antennas, terminals, screwheads, metal overlays, control shafts etc. to be sure the set is safe to operate without danger of electrical shock. Plug the AC line cord directly into a 120V AC outlet (do not use a line isolation transformer during this check). Use an AC voltmeter having 5000 ohms per volt or more sensitivity in the following manner:

Connect a 1500 ohm 10 watt resistor, paralleled by a 0.15 μ F, AC type capacitor, between a known good earth ground (water pipe, conduit, etc.) and the exposed metallic parts, one at a time. Measure the AC voltage across the combination of 1500 ohm resistor and 0.15 μ F capacitor. Reverse the AC plug at the AC outlet and repeat AC voltage measurements for each exposed metallic part. Voltage measured must not exceed 0.3 volts RMS. This corresponds to 0.2 milliamp. AC. Any value exceeding this limit constitutes a potential shock hazard and must be corrected immediately.

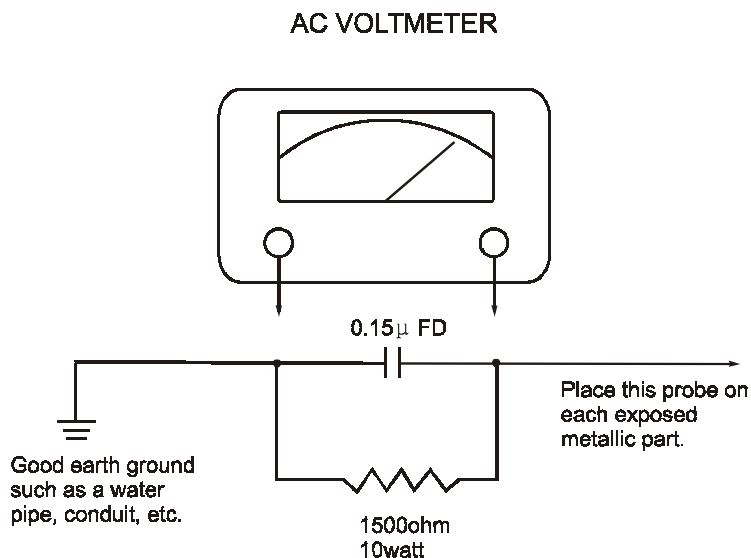

PRODUCT SAFETY NOTICE

Many electrical and mechanical parts in the chassis have special safety-related characteristics. These characteristics are often passed unnoticed by a visual inspection and the X-RAY RADIATION protection afforded by them cannot necessarily be obtained by using replacement components rated for higher wattage, etc. Replacement parts which have these special safety characteristics are identified in this manual and its supplement electrical components having such features are shaded on the schematic diagram and the parts list. Before replacing any of these components, read the parts list in this manual carefully. The use of substitute replacement parts which do not have the same characteristics as specified in the parts list may create shock, fire, X-RAY RADIATION or other hazards.

B+ CHECK

- 1) Prepare the test equipment.
- 2) Use the DC voltmeter at DC 200V position to test B+ test point, i.e. B+.

- 3) Connect the power plug to AC 120V/60Hz, turn on the power switch, wait for normal raster, Check B⁺ = 100V±0.2V.

Test point	B+	B1-5V	B2-9V	B3-10V	B4-32V	TH-12V	TH-20V	TH-200V
DC(V)	100	5	9	12	32	12	20(22)	200

INSTALLATION AND SERVICE ADJUSTMENTS

GENERAL

In the majority of cases, a color television receiver will need only slight touch – up adjustment upon installation. Check the basic characteristics such as FS, EHV, and focus. Observe the picture for good black and white details without objectionable color shading. If color shading is evident, demagnetize the receiver. If color shading still persists, perform purity and convergence adjustments. This should be all that is necessary to achieve optimum receiver performance.

FOCUS ADJUSTMENT

Adjust the FOCUS control (on T302) for well defined scanning lines on the picture screen.

HIGH VOLTAGE CHECK

CAUTION: There is no HIGH VOLTAGE ADJUSTMENT on this chassis. Checking should be done following the steps below.

1. Connect an accurate high voltage meter to the second anode of the picture tube.
2. Turn on the receiver. Set the BRIGHTNESS and CONTRAST controls to minimum (zero beam current).
3. High voltage will be measured below 9 (20")KV.
4. Vary the BRIGHNESS control to both extremes to be sure the high voltage does not exceed the limit under any conditions.

FS CIRCUIT CHECK

The Fail Safe (FS) circuit check is indispensable for the final check in the servicing. Checking should be done following the steps below.

1. Turn the power switch on and adjust customer controls for normal operation.
2. Temporarily short TP501 and TP502 on the Main Board with a jumper wire. Raster and sound will disappear.
3. The receiver must remain in this state even after removing the jumper wire. This is the evidence that the FS circuit is functioning properly.
4. To obtain a picture again, temporarily turn the receiver off and allow the FS circuit more than 30 seconds to reset. Then turn the power switch on to produce a normal picture.

Troubleshooting Guide for Fail Safe Circuit

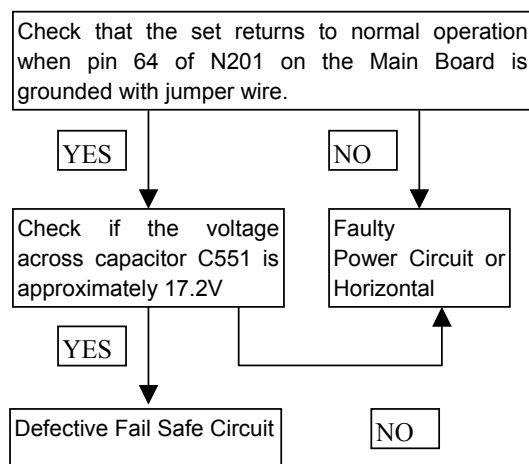

General instruction

1. This chassis' EEPROM (N801 M24C08) should copy standard data, if necessary, deal it with "factory adjustment". If directly use blank EEPROM, should first preset I²C data, then go on other common alignment. For factory adjustment method, refer to **The appendix: factory menu**.
2. If without special indication, the alignment is conducted on the below condition:
 - a) AC power supply 120 V/60 Hz.
 - b) The whole unit is preheated for more than 30 min.
3. There is built-in auto degaussing circuit, it will degauss automatically within 1second after turning on.
4. If CRT is with magnetism and affects color purity and convergence, the internal degaussing can not degauss completely, can use degaussor to degauss externally. If color purity and convergence is still poor, then do color purity and convergence adjustment.

Alignment items and procedure

1. B+ voltage check
2. RF AGC voltage adjustment
3. Focus adjustment
4. Screen-grid voltage and white balance adjustment
5. Horizontal, vertical scan center adjustment
6. Horizontal, vertical scan amplitude adjustment
7. Pattern correction adjustment
8. The alignment flow chart see figure below.

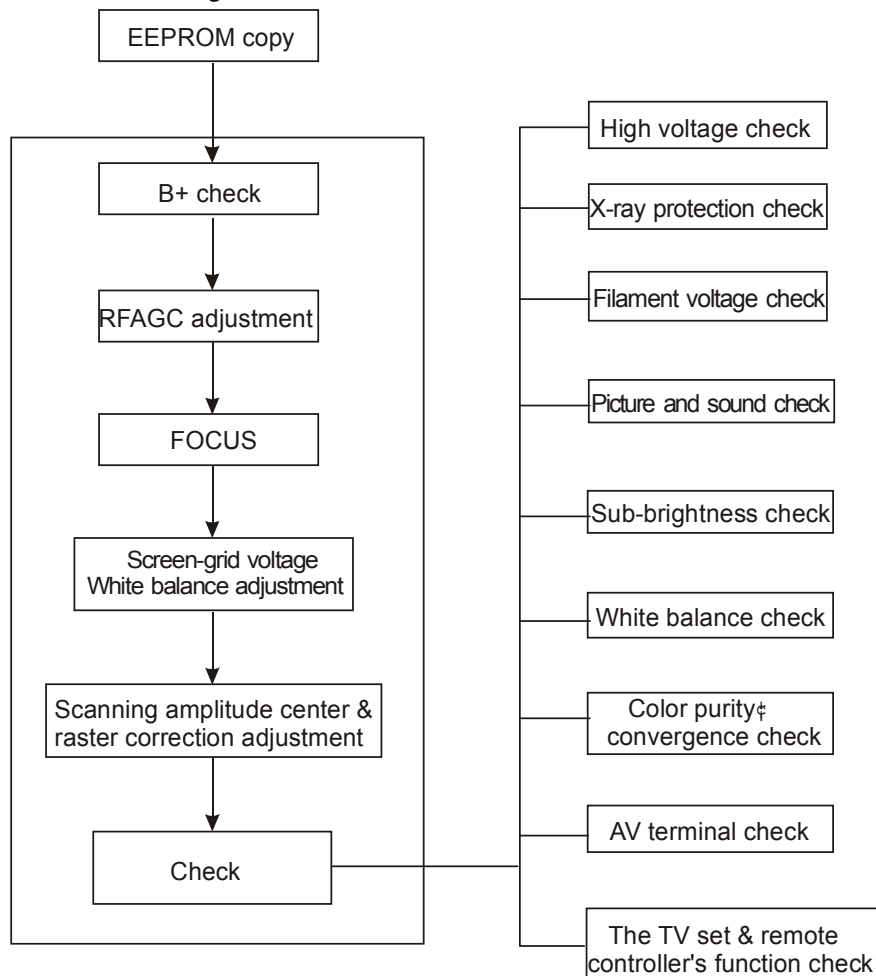

Figure 1: Alignment flow chart

Factory adjustment mode

1. B+ voltage test

- a) Make sure the AC power is 120 V/60 Hz
- b) Connect digital voltmeter to B+ test point, receive A-7 signal, set picture control to "MEMORY 2" state, test B+, the test voltage should be 100 V±0.3 V.

2. AGC adjustment

- a) Receive 60 dB split field A-7 signal.
- b) Use oscilloscope or digital voltmeter to monitor test N201 pin 43 voltage (AGC output).
- c) Press R-AGC button, by making use of [←][→] button, increase the value from low to high until the voltage just reach 4.0 V, at this time picture noisy spot should basically disappear, otherwise continue fine tune R-AGC button.

3. Focus adjustment

- 3.1 Receive A-12 signal, set user control to "MEMORY 2" state.
- 3.2 Adjust FBT's focus potentiometer, to make the screen's B area's focus optimum.

4. Accelerating electrode adjustment method (use A-7 signal)

- 4.1 Roughly adjust white balance, fix RCUT value, adjust GCUT, BCUT, GDRV, BDRV's value to make white balance basically normal.
- 4.2 Set the color to 0, contrast to 30, use oscilloscope to adjust CRT's red gun's waveform (see below figure), adjust brightness to make the seventh step's (the darkest) DC level be 180V, adjust accelerating electrode to make the seventh step slightly light up (just can separate the seventh step and below dark field).

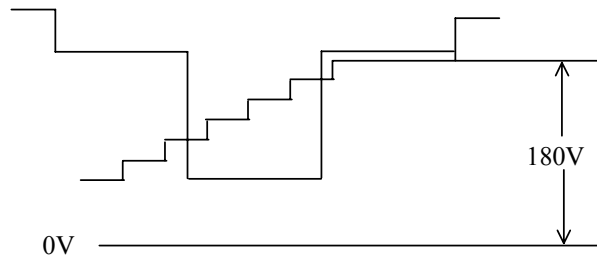

Fig 2: red gun waveform

- 4.3 Fine adjust white balance (color temperature: 12000K±8MPCD X=0.270±0.008 Y=0.283±0.008)
- 4.4 Set contrast, brightness, color all to 0, adjust BRTN to make A-7's upper left 2 lattice slightly light up.

5. Horizontal, vertical scan center adjustment

5.1 Item adjustment

- | | |
|------|-----------------------------|
| VLIN | 50Hz V-linearity adjustment |
| VSC | 50Hz Vertical S-correction |
| VLIS | 60Hz V-linearity adjustment |
| VSS | 60Hz Vertical S-correction |

5.2 PAL (50 Hz) H-center, V-center adjustment

Receive D35 signal, set user control to "MEMORY 2" state, fine tune V-center VP50, H-center HPOS, to make picture's center be in accordance with screen's center.

5.3 NTSC (60Hz) H-center, V-center adjustment

Receive A6 signal, set user control to "MEMORY 2" state, adjust V-center VP60, H-center HPS to make picture's center be in accordance with screen's center.

6. Vertical scan amplitude adjustment

6.1 PAL (50 Hz) V-amplitude adjustment

Receive D35 signal, set user control to " MEMORY 2 " state, adjust V-amplitude HIT, make picture's upper and lower overscanning be screen size's 8%.

6.2 NTSC (60 Hz) V-amplitude adjustment

Receive A 12 signal, set user control to " MEMORY 2 " state, adjust V-amplitude HITS to make picture's upper and lower overscanning be screen size's 8%.

Checking point

1. High voltage check

1.1 Connect high voltage meter to CRT's second anode and GND.

1.2 Receive A-7 signal, set user control to " MEMORY 1 " state, the high voltage should be $29.0\text{ kV} \pm 1\text{ kV}$.

1.3 When brightness and contrast be set to minimum (zero beam current), the high voltage should not exceed 32 kV.

2. CRT filament voltage check

Receive A-7 signal, set picture control to " MEMORY 2 " state, use effective value voltmeter to test CRT filament voltage, the reading should be $(6.3 \pm 0.3)\text{V}_{\text{rms}}$.

3. X-ray protection check

3.1 Receive A-7 signal, set user control to " MEMORY 2 " state.

3.2 Short R554 (TP501, TP502) X-ray protection circuit should effect.

4. Picture and sound check

4.1 Receive standard TV signal.

4.2 Making use of picture control buttons to check color, contrast, brightness, sharpness, tint's control function.

4.3 Making use of sound control buttons to check volume control function.

5. Sub-brightness check

Receive A-7 signal, set color , contrast, brightness all to 0, picture's left side first grid slightly lights.

6. This set can produce 28 kinds of testing signal by itself. Press "SLEEP PIC DSP MENU AV " button, every time you press the buttons, one kind of testing signal will be produced. The first fourteen signals are NTSC signal and the other fourteen signals are PAL signal. After these signals are cycled for one time, it will return to original screen.

7. Color purity and convergence check (Use common regulation)

8. AV terminals (AV IN/OUT check)

9. Other control buttons (on the set and on the remote controller) function check.

Preset the following in factory

1. **Picture menu:**
 - CONTRAST 100
 - BRIGHTNESS 50
 - COLOR 50
 - SHARPNESS 50
 - TINT ±00
 - PICTURE MEMORY 4
 - MODE
 - ▼MORE
2. **Volume preset to 30.**
3. **Set OSD language to English.**
4. **Color system preset to AUTO.**
5. **TV mode: channel position number 2.**
6. **Firstly press SHOP OUT D/K SPOUT out-factory button on the factory remote controller, “ready” will appear, wait for 8-10 seconds, the preset will be stored.**

Factory menu

1. **Enter into factory menu to operate.**
 - 1.1 Press “SLEEP PIC DSP MENU” button (The period of two-press should be within 5 seconds), enter into factory menu.
 - 1.2 Use MENU button to scroll the pages(P1,P2,P3).
 - 1.3 In factory menu status, press SLEEP button to exit.
2. **Factory menu contents(See below appendix 1.)**

Appendix 1 Factory menu

No	OSD character	Pre set	Adjustment item	Analogue setting	Input signal	Adjustment methods	Test point
01	RCUT	2F	Dark area white balance	Contrast 0 Color 0 Bright 50	Black/white signal Or horizontal bright line.	Make dark area obtain correct " white color "	screen
02	GCUT	4D					
03	BCUT	4B					
04	GDRV	41	Bright area white balance	MEMORY1	Black/white signal	Make dark area obtain correct " white color "	screen
05	BDRV	45					
06	HPOS	11	50Hz H-center	MEMORY2	D35		screen

07	VP50	06	50Hz V-center	MEMORY2	D35	Adjust to make picture's vertical and horizontal center be in accordance with CRT center.	
08	HIT	25	50Hz V-amplitude	MEMORY2	D35	Make V-amplitude meet checking standard	screen
09	VLIN	0B	V-linearity	MEMORY2	Cross-hatch signal (PAL)	Adjust to make screen's upper and lower cross-hatch height be equal.	screen
10	VSC	05	Vertical S-correction	MEMORY2	Cross-hatch signal (PAL)	Adjust to make screen's upper and middle and lower cross-hatch height be equal.	screen
11	HPS	03	60Hz H-center	MEMORY2	A6	Adjust to make picture's vertical and horizontal center be in accordance with CRT center.	screen
12	VP60	03	60Hz V-center	MEMORY2	A6	Adjust to make picture's vertical and horizontal center be in accordance with CRT center.	screen
13	HITS	02	60Hz V-amplitude	MEMORY2	A12	To make V-amplitude meet checking standard.	screen
14	VLIS	00	60Hz V-linearity fine tune	MEMORY2	Cross-hatch signal (NTSC)	Adjust to make screen's upper and lower cross-hatch height be equal.	screen
15	VSS	02	60Hz Vertical S-correction	MEMORY2	Cross-hatch signal (NTSC)	Adjust to make screen's upper and middle and lower cross-hatch height be equal.	Screen
16	RAGC	29	RF AGC adjustment	MEMORY2	A7	Adjust to make picture without noise	N201(43)
17	HAFC	03	1/2 AFC data adjustment		A12	Fix	
18	V25	42	25% volume adjustment		A21	Fix	
19	V50	4E	50% volume adjustment		A21	Fix	
20	TXCX	3F	YUV sub-color maximum value	Bright 50 Color 100 Contrast 50	In any signal will display MENU	Let character not defocusing	Screen
21	RGCN	16	YUV sub-color minimum value	Bright 50 Color 0 Contrast 50	Let picture without color	Let character clear	Screen
22	ABL	23	Auto brightness limitation	MEMORY1	A7	fix	Screen

23	DCBS	42	BIT4,5 OSD character brightness level				
			BIT2,3 Ygamma value				
			BIT 0,1 black level stretch value				
24	CNTX	50	Sub-contrast maximum value	MEMORY1	Gray scale	Fix	Screen
25	CNTC	3F	Sub-contrast middle value	Contrast 50	Gray scale	Fix	Screen
26	CNTN	0F	Sub-contrast minimum value	Contrast 0 Color 0 Bright 50	Gray scale	Fix	Screen
27	SCNT	0F	Sub-contrast	Natural	Gray scale	Fix	Screen
28	BRTX	1A	Sub-bright maximum value	Contrast 50 Bright 100 Color 0	A7	Fix	Screen
29	BRTC	2D	Bright middle value	MEMORY2	A7	Fix	Screen
30	BRTN	20	Sub-bright minimum value	Contrast 50 Bright 0 Color 0	A7	Fix	Screen
31	BRTS	1C	Sub-bright	Contrast 0 Bright 50 Color 0	A7	Fix	Screen
32	COLX	7F	Sub-color maximum value	Contrast 50 Bright 50 Color 100	D8 A7	Fix	Screen
33	COLC	40	Sub-color middle value	Natural	A7	Fix	Screen
34	COLP	00	PAL sub-color middle value	Natural	D8	Fix	Screen
35	COLN	00	Sub-color minimum value	Contrast 50 Bright 50 Color 0	A7	Let picture without color	Screen
36	TNTX	50	Sub-tint maximum value	Contrast 100 Bright 50 Color 50 Tint 100	A7	Fix	Screen
37	TNTC	50	Sub-tint middle value	Natural	A7	Fix	Screen
38	TNTN	50	Sub-tint minimum	Contrast 100	A7	Fix	Screen

			value	Bright 50 Color 50 Tint 0			
39	TNCD	40	DVD Tint middle value	Contrast 100 bright 50 Color 50 Tint 0	DVD	Fix	Screen
40	SHPX	3F	Sub-sharpness maximum value	Sharpness 100	A12	Fix	Screen
41	SHPN	10	Sub-sharpness minimum value	Sharpness 0	A12	Fix	Screen
42	ST3	2E	NTSC3.58 TV input signal's sharpness middle value	MEMORY1	Video input NTSC3.5 signal	Fix	Screen
43	SV3	2E	NTSC3.58 AV input signal's sharpness middle value.	MEMORY1	Video input NTSC3.5 signal	Fix	Screen
44	ST4	2E	Non NTSC3.58 TV input signal's sharpness middle value	MEMORY1	A12, B12	Fix	Screen
45	SV4	2E	Non NTSC 3.58 AV input signal's sharpness middle value.	MEMORY1	Video input PAL signal	Fix	Screen
46	SVD	19	DVD sharpness middle value			Fix	Screen
47	DEF	01	0: picture parallel 1: picture non-parallel		Cross-hatch signal	Fix	
48	STBY	00	Decoder intermediate amplifier STANDBY				
49	ASSH	00	Single side sharpness				
50	VBLK	00	Vertical blinking beginning point, ending point.				

51	MOD	03	Mode data				
52	UCOM	00	Chroma auto-phase control setting				
53	NOIS	01	Noise check				
54	SYCT	08	Sync signal check				
55	TUNR	02	Tuner selection				
56	CCD_ OSD	50	CCD(concealed caption) OSD beginning position				
57	CCD_ OSDF	50	CCD character size				
58	OSDF	4F	OSD character size				
59	OSD	15	OSD position				
60	OPT	07					
61	OPTM1	A3					
62	OPTM2	13					
<p>Note 1: The original password CHILD LOCK MENU 0000, VCHIP PASSWORD 0000.</p>							

CONVERGENCE MAGNET ASSEMBLY POSITIONING

Convergence magnet assembly and rubber wedges need mechanical positioning. Refer to below figure 1.

COLOR PURITY ADJUSTMENT

NOTE: Before attempting any purity adjustment, the receiver should be operated for at least fifteen minutes.

1. Demagnetize the picture tube and cabinet using a degaussing coil.
2. Set the CONTRAST and BRIGHTNESS controls to the maximum.
3. Receive PM5515 monochromatic signal (such as G) to provide a green raster on the screen.
4. Loosen the clamp screw holding the yoke, and slide the yoke backward to provide vertical green belt (zone) in the picture screen.
5. Remove the Rubber Wedges.
6. Rotate and spread the tabs of the purity magnet around the neck of the picture tube until the green belt is in the center of the screen. At the same time, center the raster vertically by adjusting the magnet.
7. Move the yoke slowly forward or backward until a uniform green screen is obtained. Tighten the clamp screw of the yoke temporarily.
8. Check the purity of the red and blue raster.
9. Obtain a white raster, referring to "CRT WHITE BALANCE ADJUSTMENT".
10. Proceed with convergence adjustment.

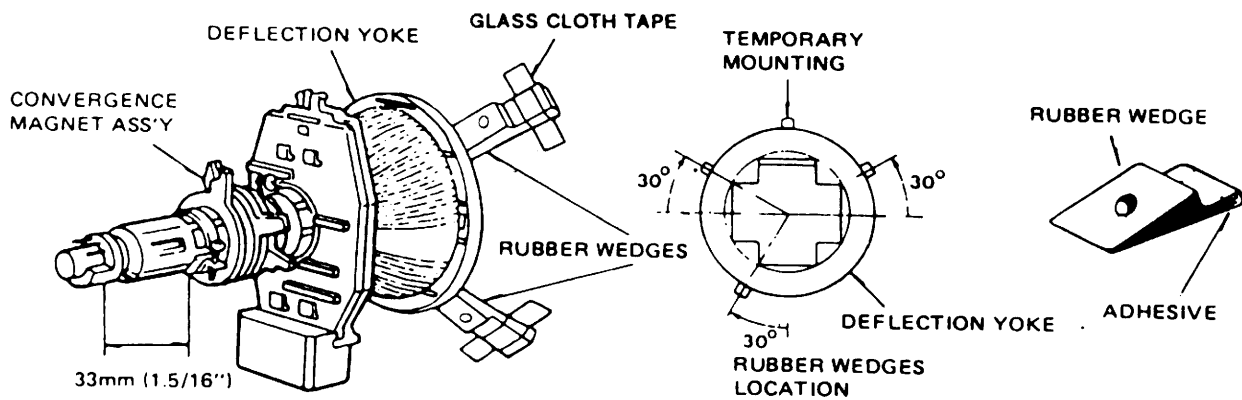

Fig.3

CONVERGENCE ADJUSTMENT

NOTE: Before attempting any convergence adjustments, the receiver should be operated for at least fifteen minutes.

CENTER CONVERGENCE ADJUSTMENT

1. Receive crosshatch pattern with a color bar signal generator.
2. Adjust the BRIGHTNESS and CONTRAST controls for well defined pattern.
3. Adjust two tabs of the 4-Pole Magnets to change the angle between them (see figure 4) and superimpose red and blue vertical lines in the center area of the picture screen. (see figure 5)
4. Turn the both tabs at the same time keeping the constant angle to superimpose red and blue horizontal lines at the center of the screen.(see figure 5)
5. Adjust two tabs of 6-Pole Magnets to superimpose red/blue line with green one. Adjusting the angle affects the vertical lines and rotating both magnets affects the horizontal lines.
6. Repeat adjustments 3,4,5, keeping in mind red, green and blue movement, because 4-Pole Magnets and 6-Pole Magnets interact and make dot movement complex.

CIRCUMFERENCE CONVERGENCE ADJUSTMENT

1. Loosen the clamping screw of deflection yoke to allow the yoke to tilt.
2. Put a wedge as shown in figure 1 temporarily. (Do not remove cover paper on adhesive part of the wedge.)
3. Tilt front of the deflection yoke up or down to obtain better convergence in circumference. (See figure 5). Push the mounted wedge into the space between the picture tube and the yoke to hold the yoke temporarily.
4. Put other wedge into bottom space and remove cover paper to stick.
5. Tilt front of the yoke right or left to obtain better convergence in circumference (see figure 5)
6. Keep the yoke position and put another wedge in either upper space. Remove cover paper and stick the wedge on the picture tube to fix the yoke.
7. Detach the temporarily mounted wedge and put it in another upper space. Stick it on the picture tube to fix the yoke.
8. After fixing three wedges, recheck overall convergence. Tighten the screw firmly to fix the yoke tightly in place.

9. Stick three adhesive tapes on wedges as shown in figure 3.

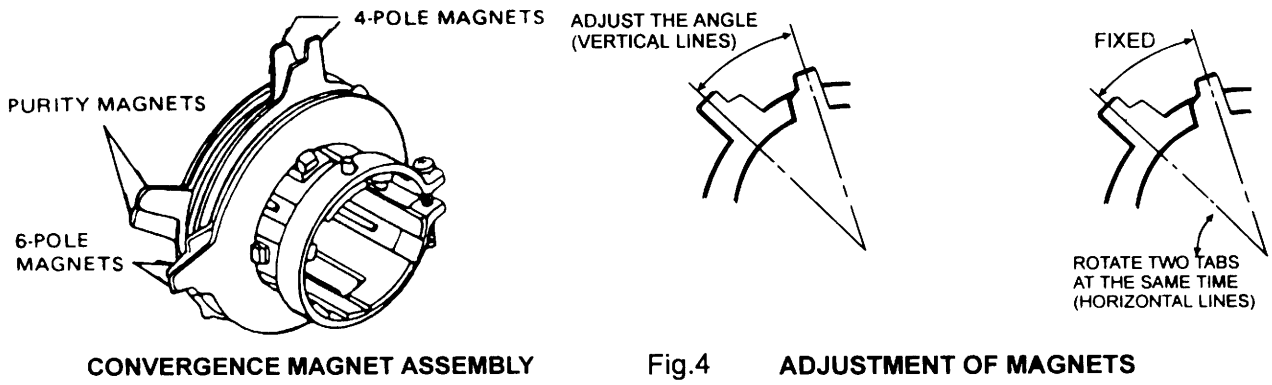

Fig.4

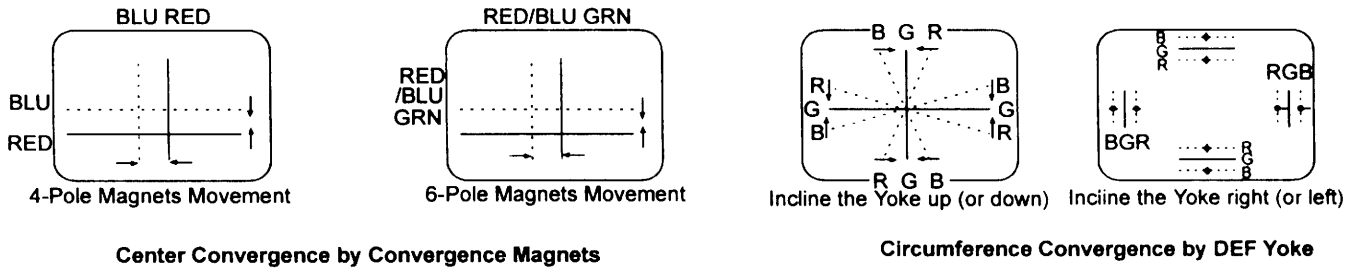

Fig.5 Dot Movement Pattern

USA CHANNEL FREQUENCY TABLE (181 CH)

P IF=45.75 MHz

C IF=42.17MHz

S IF=41.25MHz

UNIT: MHz

BAND	CHANNEL	P CARRIER	S CARRIER	LOCAL
VHF Low	2	55.25	59.75	101
	3	61.25	65.75	107
	4	67.25	71.75	113
	5	77.25	81.75	123
	6	83.25	87.75	129
	A-6	85.25	89.75	131
	A-5	91.25	95.75	137
	A-4	97.25	101.75	143
	A-3	103.25	107.75	149
	A-2	109.25	113.75	155
	A-1	115.25	119.75	161
	A	121.25	125.75	167
	B	127.25	131.75	173
	C	133.25	137.75	179
VHF High	D	139.25	143.75	185
	E	145.25	149.75	191
	F	151.25	155.75	197
	G	157.25	161.75	203
	H	163.25	167.75	209
	I	169.25	173.75	215
	7	175.25	179.75	221
	8	181.25	185.75	227
	9	187.25	191.75	233
	10	193.25	197.75	239
	11	199.25	203.75	245
	12	205.25	209.75	251
	13	211.25	215.75	257
	J	217.25	221.75	263
	K	223.25	227.75	269
	L	229.25	233.75	275
	M	235.25	239.75	281
	N	241.25	245.75	287
	O	247.25	251.75	293
	P	253.25	257.75	299
	Q	259.25	263.75	305
	R	265.25	269.75	311
	S	271.25	275.75	317
	T	277.25	281.75	323
	U	283.25	287.75	329
	V	289.25	293.75	335
	W	295.25	299.75	341
	W+1	301.25	305.75	347
	W+2	307.25	311.75	353
	W+3	313.25	317.75	359
	W+4	319.25	323.75	365
	W+5	325.25	329.75	371
	W+6	331.25	335.75	377
	W+7	337.25	341.75	383
W+8	343.25	347.75	389	
W+9	349.25	353.75	395	
W+10	355.25	359.75	401	

BAND	CHANNEL	P CARRIER	S CARRIER	LOCAL
UHF	W+11	361.25	365.75	407
	W+12	367.25	371.75	413
	W+13	373.25	377.75	419
	W+14	379.25	383.75	425
	W+15	385.25	389.75	431
	W+16	391.25	395.75	437
	W+17	397.25	401.75	443
	W+18	403.25	407.75	449
	W+19	409.25	413.75	455
	W+20	415.25	419.75	461
	W+21	421.25	425.75	467
	W+22	427.25	431.75	473
	W+23	433.25	437.75	479
	W+24	439.25	443.75	485
	W+25	445.25	449.75	491
	W+26	451.25	455.75	497
	W+27	457.25	461.75	503
	W+28	463.25	467.75	509
	W+29	469.25	473.75	515
	14	471.25	475.75	517
	15	477.25	481.75	523
	16	483.25	487.75	529
	17	489.25	493.75	535
	18	495.25	499.75	541
	19	501.25	505.75	547
	20	507.25	511.75	553
	21	513.25	517.75	559
	22	519.25	523.75	565
	23	525.25	529.75	571
	24	531.25	535.75	577
	25	537.25	541.75	583
	26	543.25	547.75	589
	27	549.25	553.75	595
	28	555.25	559.75	601
	29	561.25	565.75	607
	30	567.25	571.75	613
	31	573.25	577.75	619
	32	579.25	583.75	625
	33	585.25	589.75	631
	34	591.25	595.75	637
	35	597.25	601.75	643
	36	603.25	607.75	649
	37	609.25	613.75	655
	38	615.25	619.75	661
	39	621.25	625.75	667
40	627.25	631.75	673	
41	633.25	637.75	679	
42	639.25	643.75	685	
43	645.25	649.75	691	
44	651.25	655.75	697	
45	657.25	661.75	703	

USA CHANNEL FREQUENCY TABLE (181 CH)

P IF=45.75 MHz

C IF=42.17MHz

S IF=41.25MHz

UNIT: MHz

BAND	CHANNEL	P CARRIER	S CARRIER	LOCAL
UHF	46	663.25	667.75	709
	47	669.25	673.75	715
	48	675.25	679.75	721
	49	681.25	685.75	727
	50	687.25	691.75	733
	51	693.25	697.75	739
	52	699.25	703.75	745
	53	705.25	709.75	751
	54	711.25	715.75	757
	55	717.25	721.75	763
	56	723.25	727.75	769
	57	729.25	733.75	775
	58	735.25	739.75	781
	59	741.25	745.75	787
	60	747.25	751.75	793
	61	753.25	757.75	799
	62	759.25	763.75	805
	63	765.25	769.75	811
	64	771.25	775.75	817
	65	777.25	781.75	823
	66	783.25	787.75	829
	67	789.25	793.75	835
	68	795.25	799.75	841
	69	801.25	805.75	847

WIRING DIAGRAM

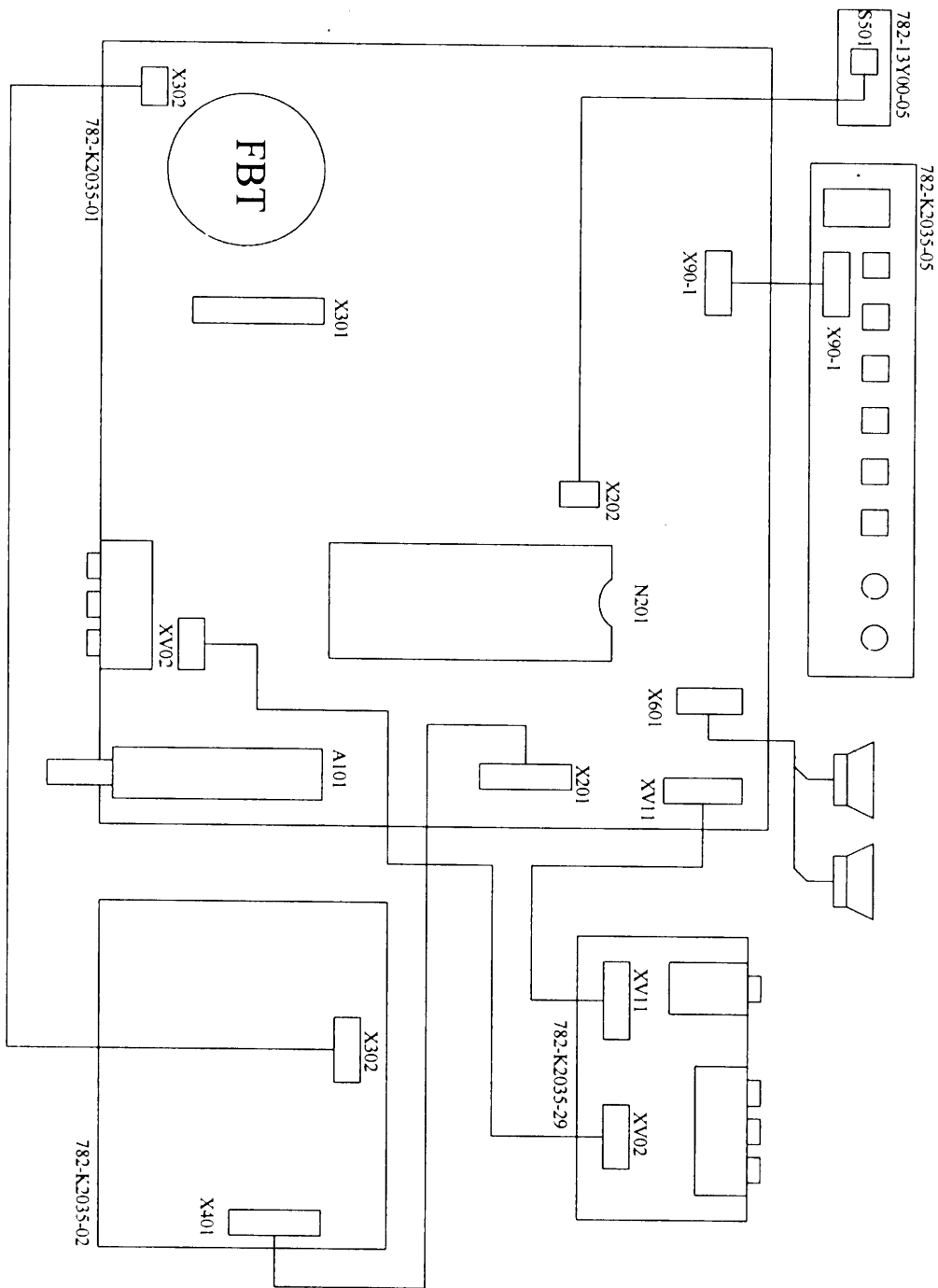

BLOCK DIAGRAM

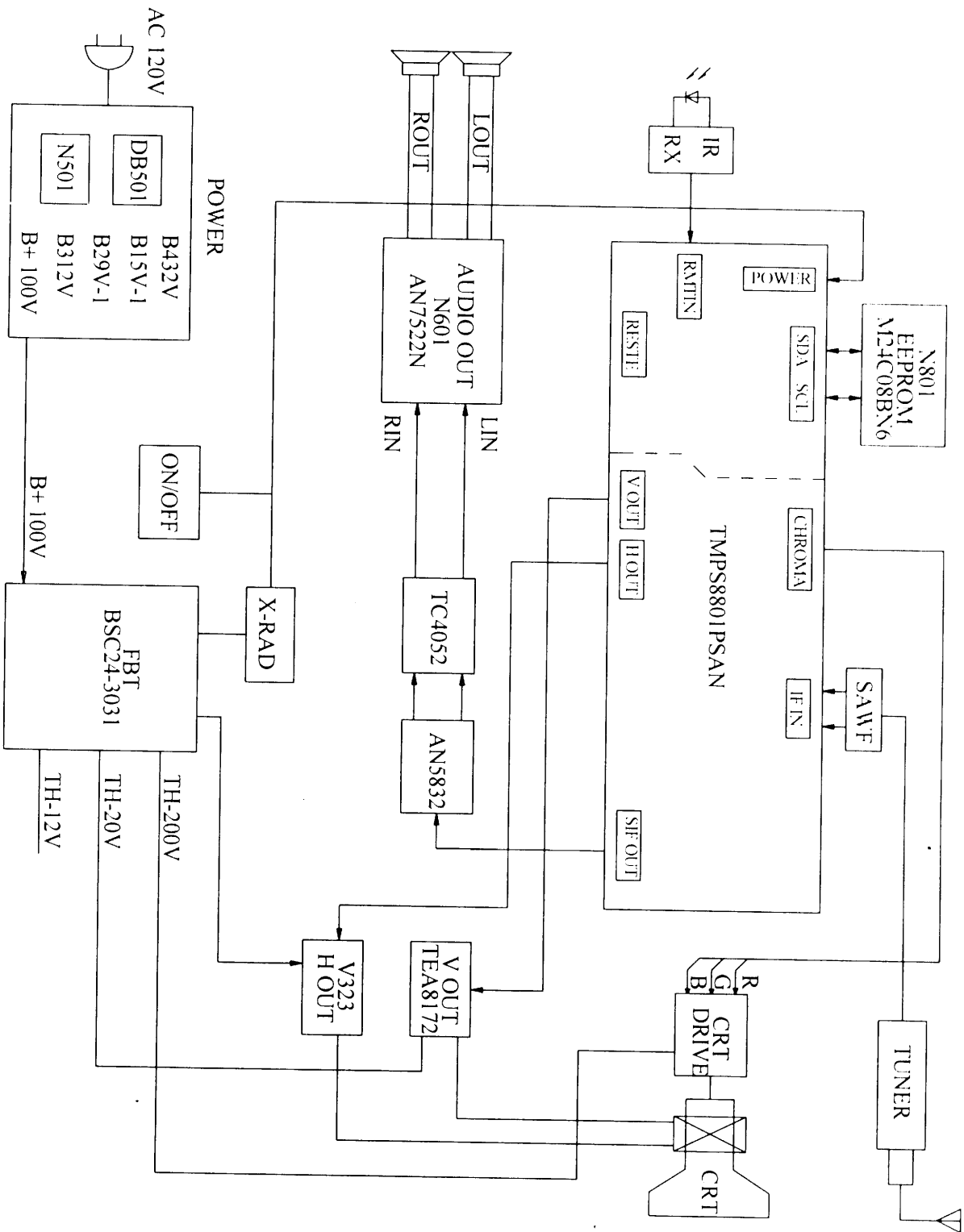

IC BLOCK DIAGRAM

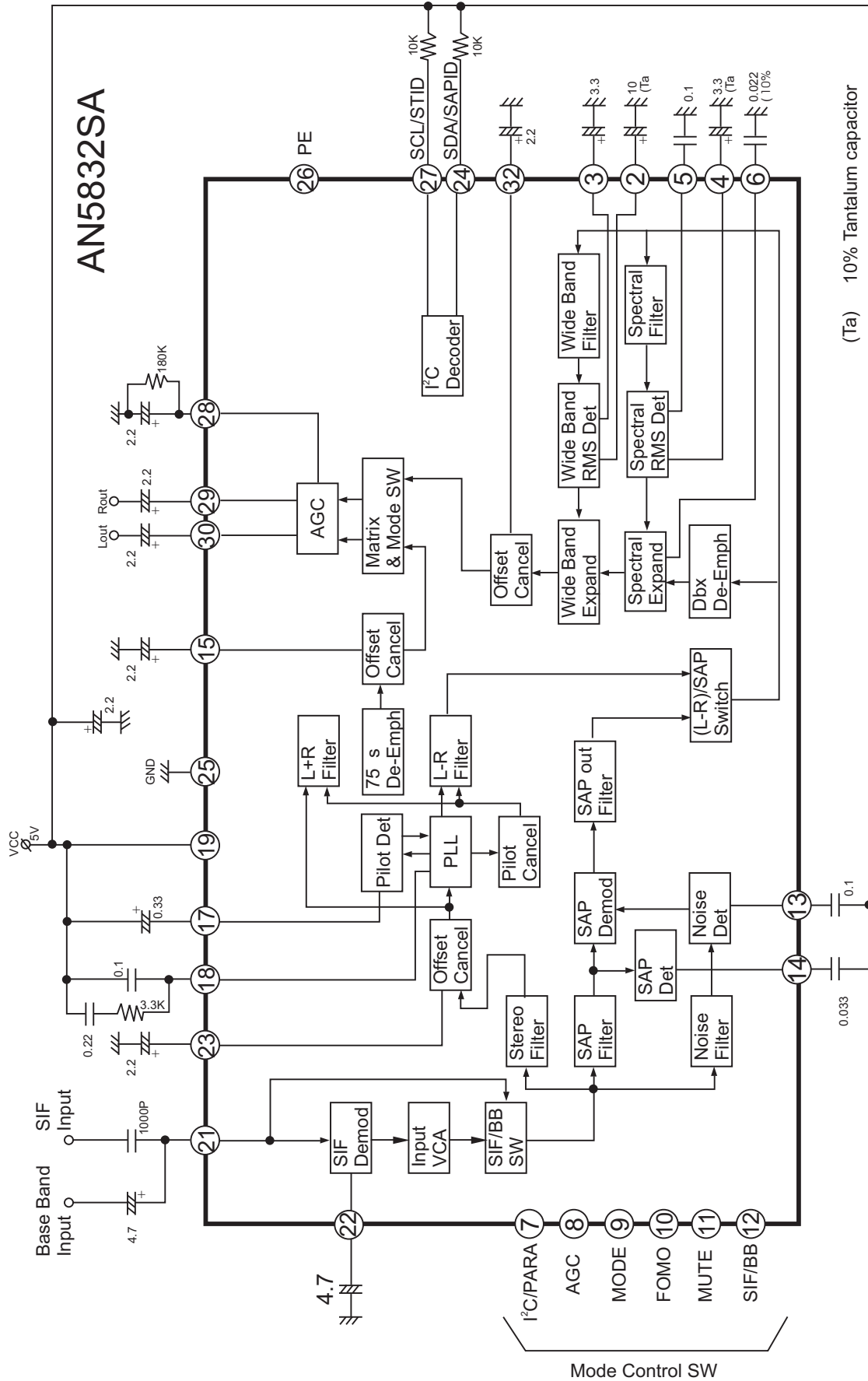

TMPA8801PSN(PN)

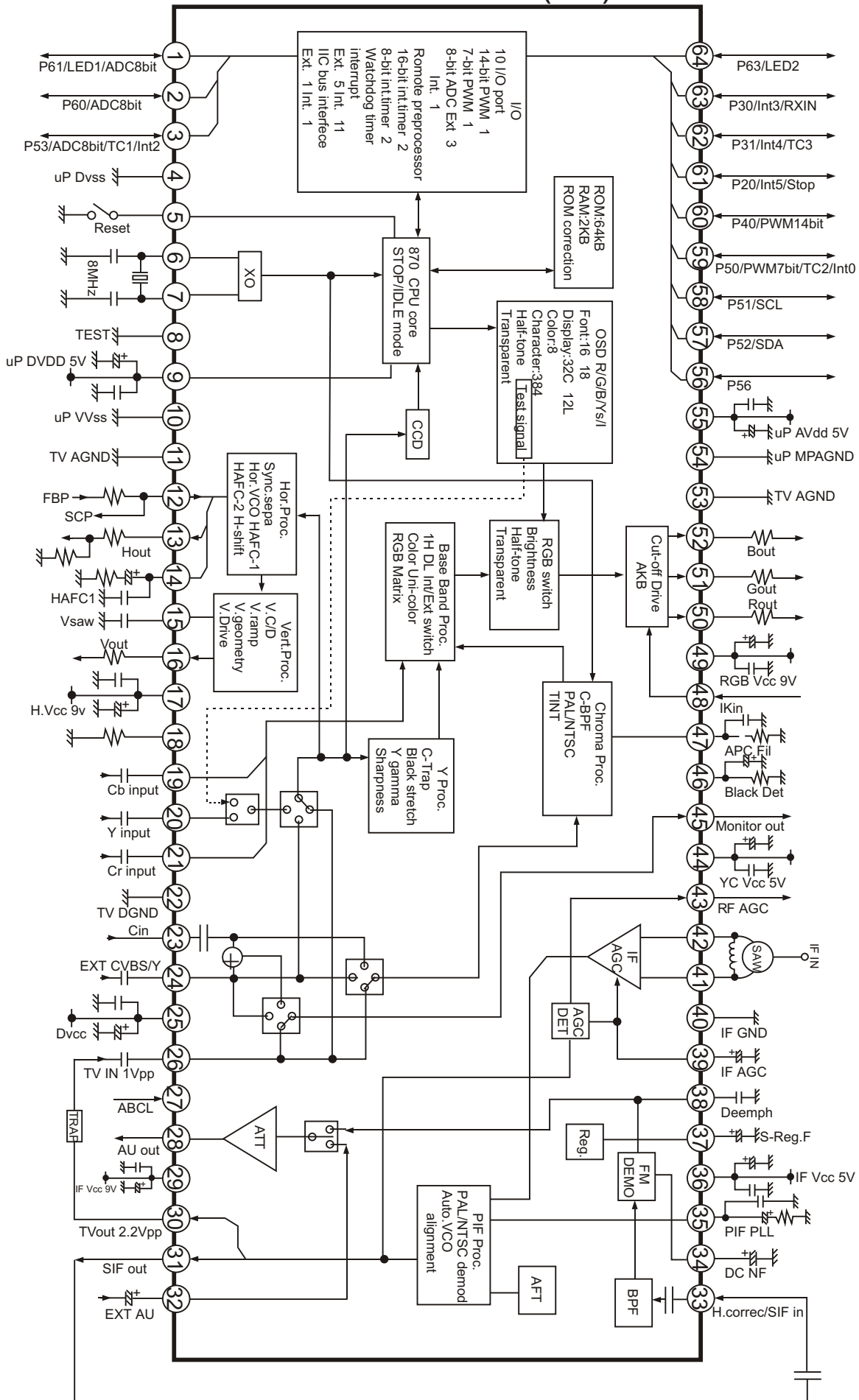

STR-G5653

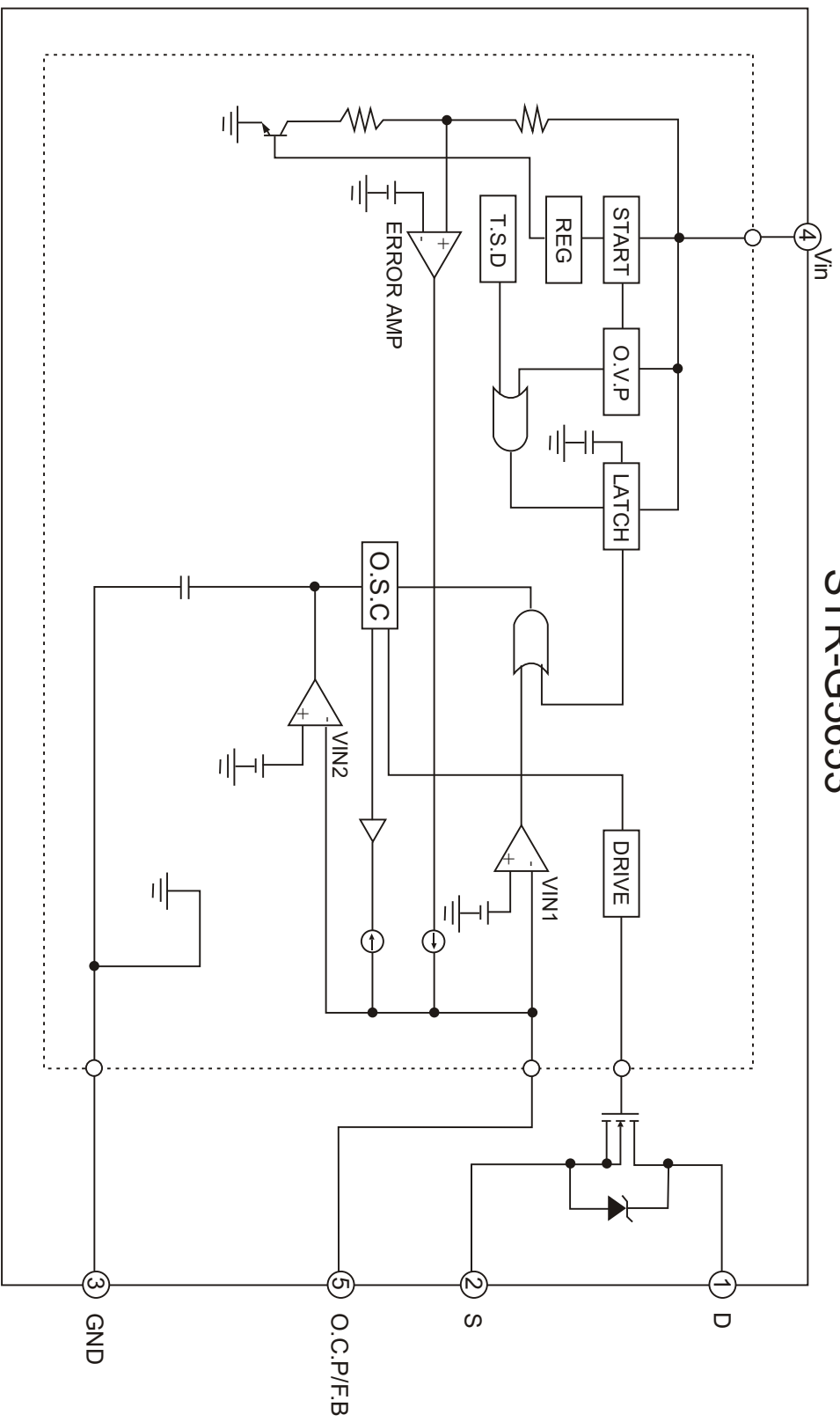

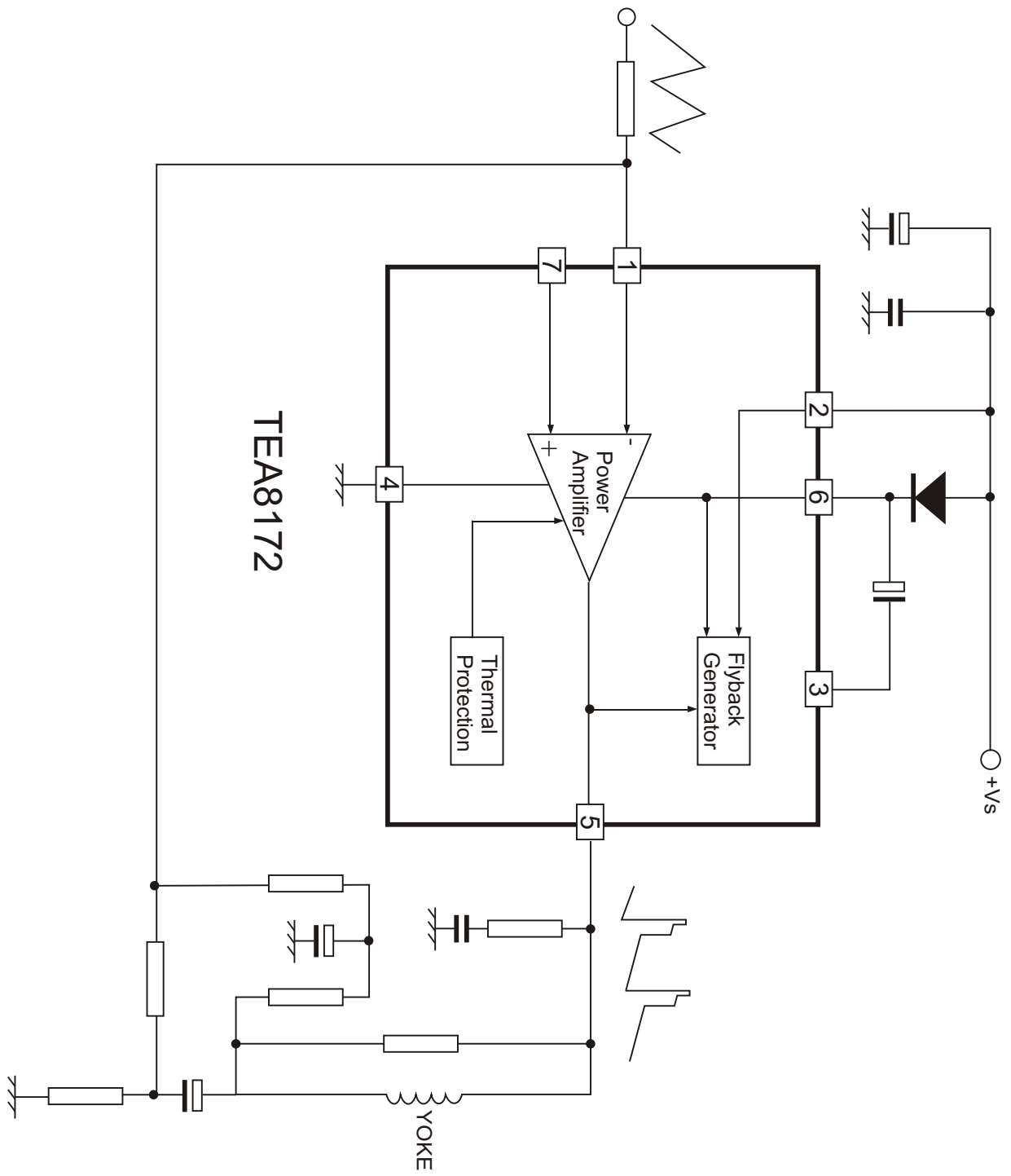

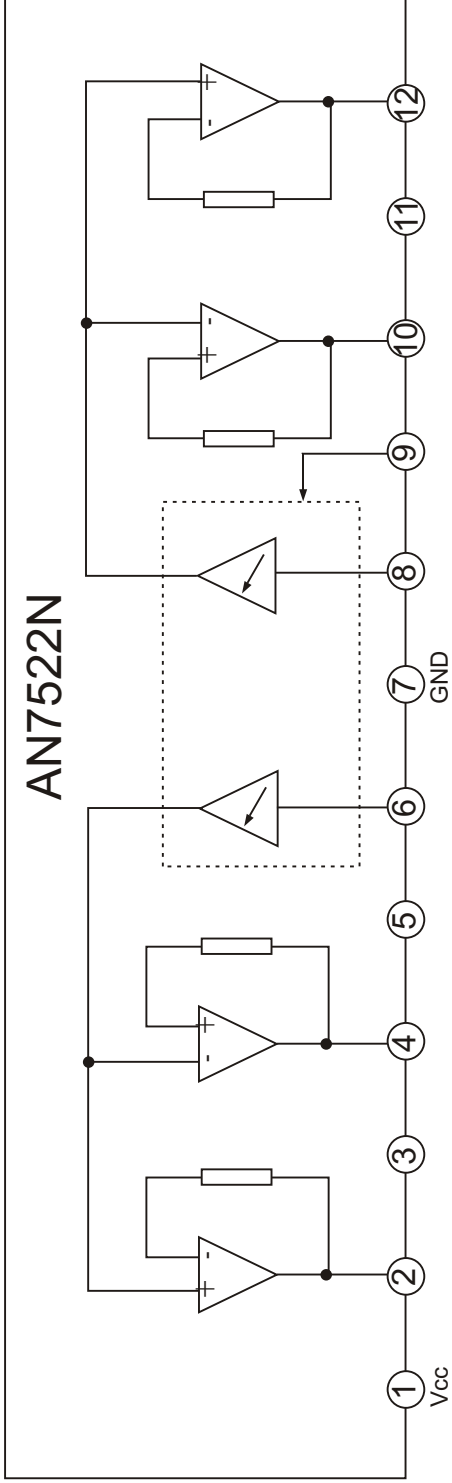

THE IC PIN'S VOLTAGE IN NORMAL/STAND BY WORKING MODE (120V,PRESNET MODE)

1、TMPS8801(N201)

PIN	Voltage (V) Normal	Voltage (V) Stand by	PIN	Voltage (V) Normal	Voltage (V) Stand by
1	5.69	5.63	33	3.04	
2	5.69	5.62	34	2.55	
3	5.68	5.61	35	2.48	
4	0	0	36	5.20	
5	5.69	5.62	37	2.25	
6	2.52	5.60	38	4.5	
7	2.29	2.49	39	1.77	
8	0	2.26	40	0	
9	5.69	5.60	41	0.10	
10	0	0	42	0.10	
11	0		43	2.11	
12	1.06		44	5.19	
13	1.81		45	1.84	
14	6.81		46	2.46	
15	4.21		47	2.66	
16	5.03		48	1.37	
17	9.19		49	1.37	
18	0		50	9.23	
19	2.56		51	2.41	
20	2.57		52	2.48	
21	2.56		53	2.59	
22	0		54	0	0
23	0		55	5.70	5.60
24	2.55		56	0.06	5.56
25	3.52		57	5.33	5.54
26	2.77		58	5.23	5.50
27	4.71		59	0.01	0
28	3.60		60	2.20	5.56
29	9.24		61	0	0.04
30	3.73		62	5.04	5.59
31	1.91		63	5.64	5.55
32	0		64	0	1.04

2、AN5832(NS01)

PIN	Voltage (V)	PIN	Voltage (V)
1	Empty	17	3.23
2	0.73	18	3.58
3	2.76	19	5.20
4	0.60	20	Empty
5	2.45	21	3.67
6	2.03	22	3.48
7	5.20	23	2.25
8	Empty	24	5.14
9	Empty	25	0
10	Empty	26	Empty
11	Empty	27	4.90
12	Empty	28	1.89
13	3.45	29	2.22
14	3.46	30	2.22
15	2.28	31	Empty
16	Empty	32	2.12

3、AN7522N(N601)

PIN	Voltage (V)	
1	10.52	
2	4.66	
3	0	
4	4.68	
5	8.18	0.44
6	1.49	
7	0	
8	1.48	
9	0.43	
10	4.62	
11	0	
12	4.61	

4、TEA8172 (N301)

PIN	Voltage
1	3.75
2	20.6
3	1.53
4	0.01
5	12.86
6	20.9
7	3.76

5、TC4052(TV)

PIN	Voltage	PIN	Voltage
1	4.30	9	0.05
2	0.27	10	0.01
3	0.75	11	0
4	Empty	12	0.74
5	0.22	13	0.74
6	0	14	0.6
7	0	15	0.13
8	0	16	9.23

6、STR-G5653(N501)Voltage(V) 7、TDQ-3B8GN (A101)

PIN	1	2	3	4	5
Standby	135	0	0	20	0
Voltage	18	0	0	32	5

1	3	4	5	6/7	9	11
AGC	AS	SCL	SDA	BM1/2	BT	IF
2.1	5.0	5.7	5.3	5.03	32	0

The triode pin's voltage in normal working mode (120v、PRESENT Mode. Parenthesis means stand by)

Symbol	Type	Voltage (V)		
		C	E	B
V101	2SC2717	7.38	0.24	1
V206	C1815Y	9.23	1.97	2.59
V207	C1815Y	9.23	1.85	2.48
V208	C1815Y	9.23	1.79	2.41
V401	2SC2688	164.6	1.46	1.77
V402	2SC2688	161.4	1.53	1.84
V403	2SC2688	156.4	1.64	1.95
V404	2SC1815Y	2.81	0.01	0.01
V801	2SA1015	0	2.52	1.84
V802	2SA1015	2	9.16	9.18
V803	C1815	4.95	0	0.24
V810	A562TM-0	5.7	5.71	5.03
V601	C1815-Y	0.55	0	0
V509	2SA1015	0	13.06	13.13
V508	SFORIB42	0.01	0.03	0.01
V201	C1815Y	9.24	3.02	3.72
V205	2SA1015Y	0	3.75	3.07
VV01	2SA1015	0	0.7	0.03
V203	C1815Y	9.24	3.68	4.34
V501	2SA1015	9.89(7.41)	13.14(7.56)	12.56(6.77)
V502	2SC1815-Y	12.56(0)	0.01(0)	0.03(0.68)
V505	2SC3807	13.14(7.5)	9.21(0)	9.77(0.13)
V507	2SC3807	9.89(7.3)	5.72(5.5)	6.26(6.0)
V506	2SC1815- BL	9.77(0.2)	0.01(0)	0.03(0.7)
V324	C3807	7.03	5.33	5.89
V322	C2383-0	21.2	0.01	0.4
N303	78M09	13(1pin)	0(2pin)	9(3pin)

COMPONENT AND BOTTOM VIEW

COMPONENT VIEW OF MAIN BOARD

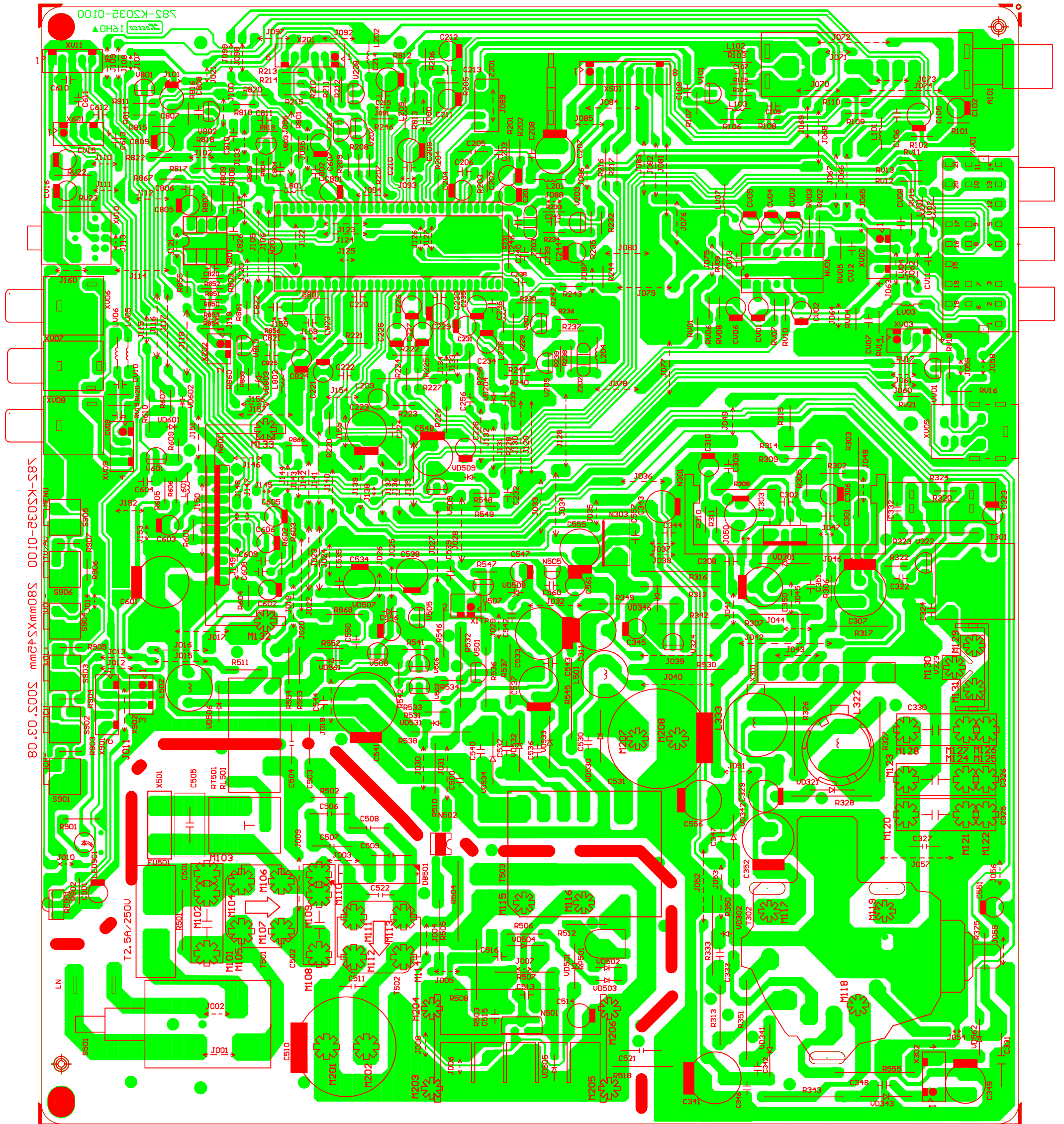

BOTTOM VIEW OF MAIN BOARD

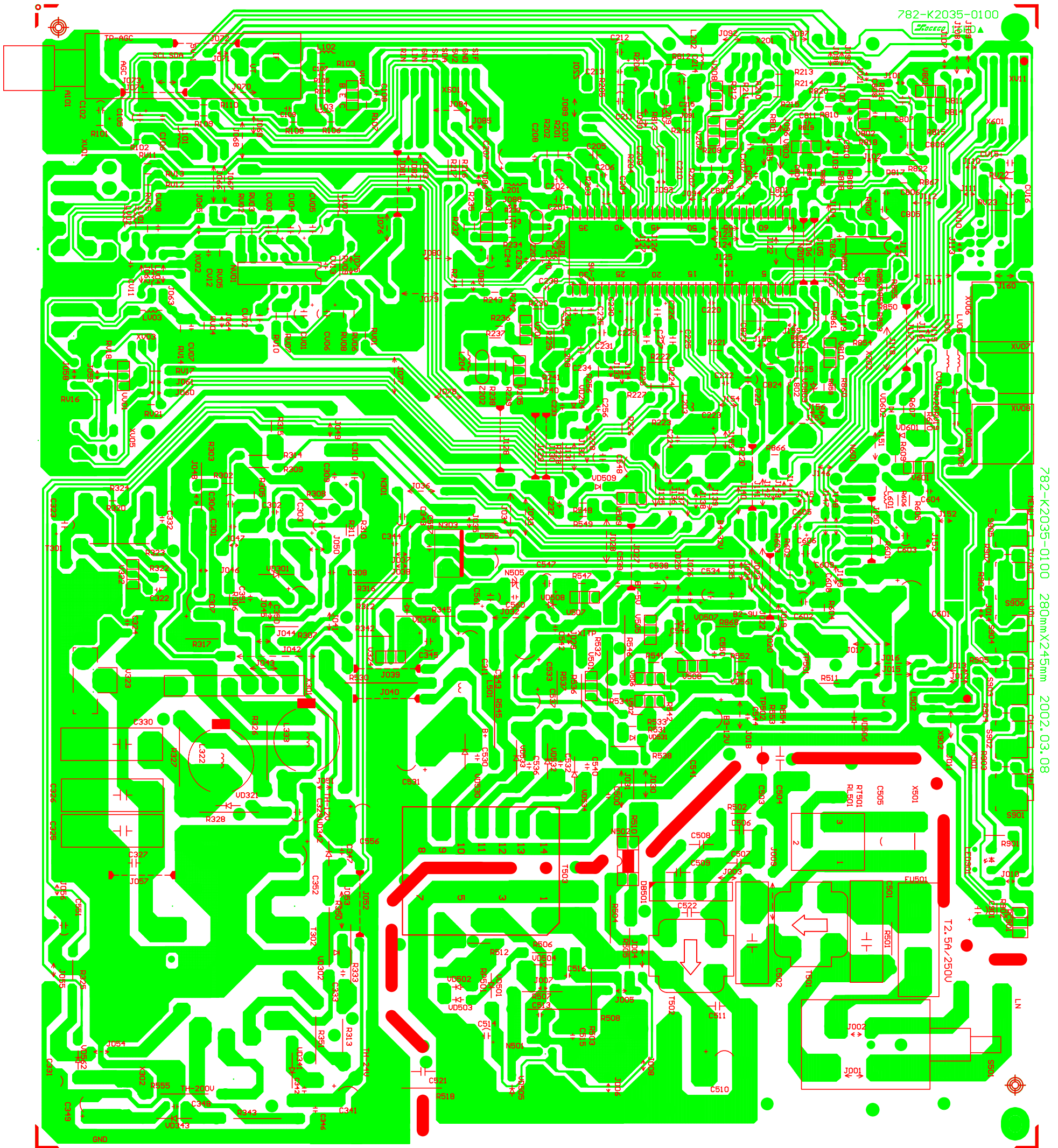









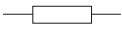
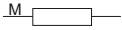
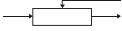

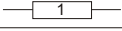
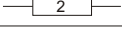
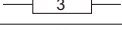
782-K2035-0100
782-K2035-0100

280mmX245mm 2002.03.08

CAUTION: All the parts in the schematic diagram marked with red frame and the signs of \triangle are extremely important a safety. In case of replacement of any part of the components. Be sure to consult the service manual carefully.

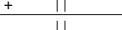
1. The schematic diagram is characteristic. The various values in the electric circuits are basic data, which are changeable according to the various basic circuits.
2. Testing waves are obtained by inputting the standard color bar of the signed.
3. Resistance unit is in Ohm, namely:
 $K=1000$ $M=1000K$
 Capacitance unit is in μF .
 $P=\mu\mu F (\mu=10^{-6})$
4. Unless otherwise noted inside, all resistors are 1/6W, the withstand voltage of all capacitor are 50V.
5. Inductance unit is in μH .
6. The mark \rightleftharpoons in the diagram means Ferrite ring.
7. The symbols of various types of resistors and capacitors are listed as follows:

Carbon Film	
Metal Film	
Potentiometer	
1/2W	
1W	
2W	
3W	
Ceramic	
AC Ceramic	
Ployester	
Ploypropylene	
Metal Polyester	
Aluminium	
Tantalum	

NTSC
2001.11.26

SCHEMATIC DIAGRAM

782-K2035-0100

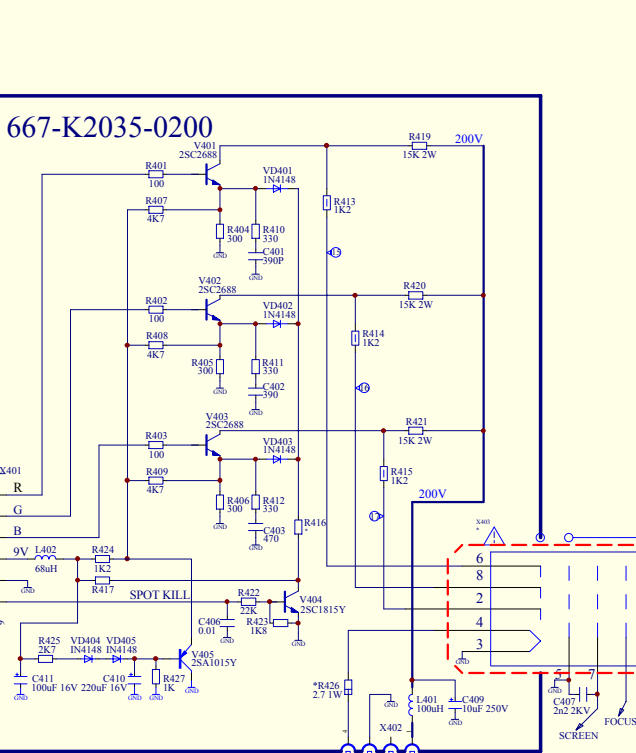
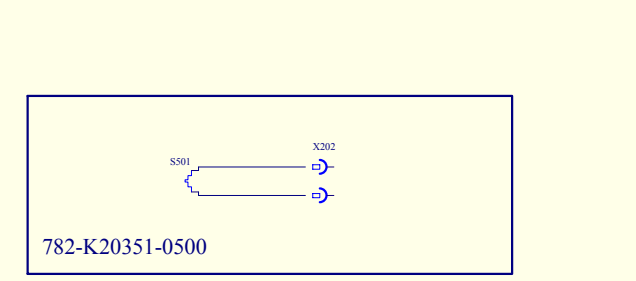
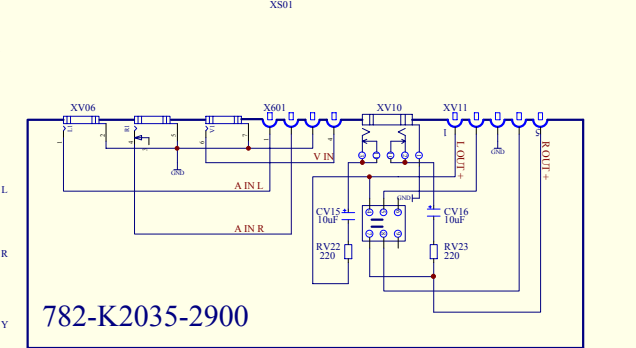
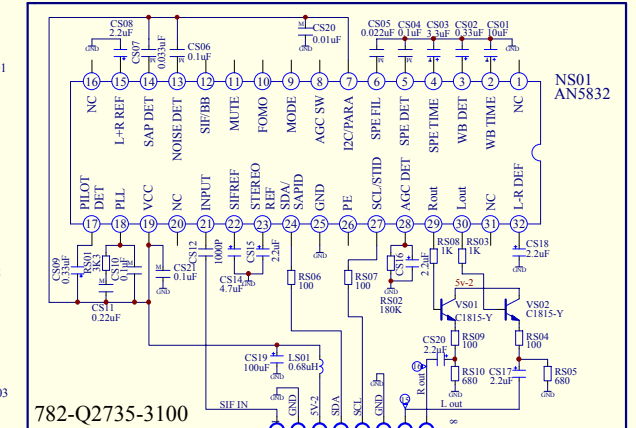
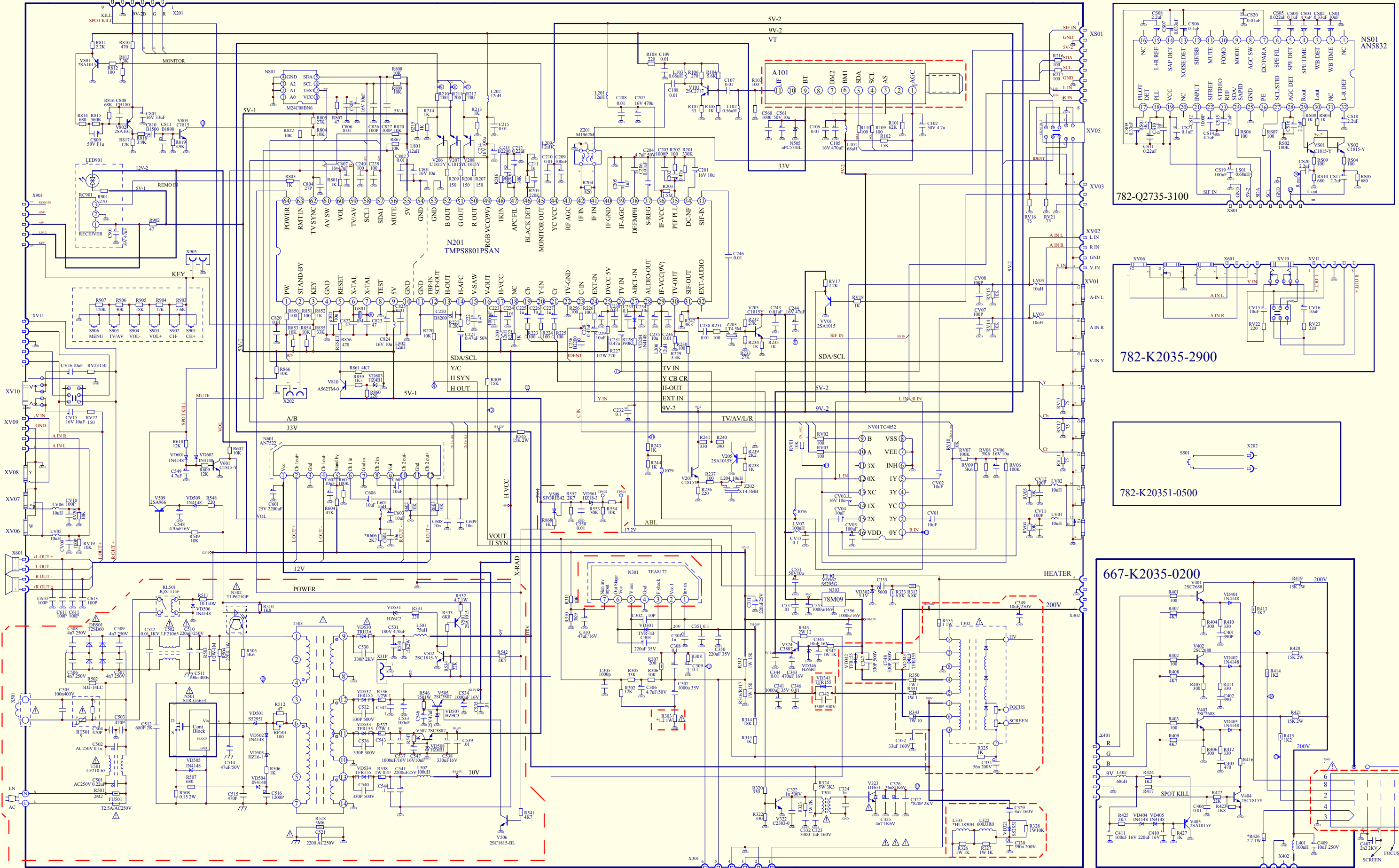

2002.04.22

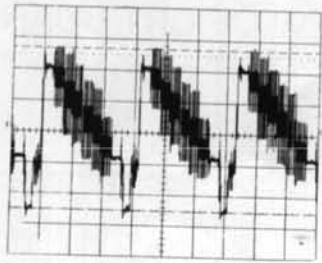

(1) 1V_{p,p}

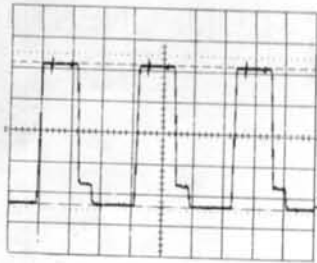

(2) 4.5V_{p,p}

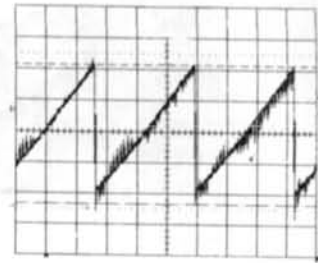

(3) 2.2V_{p,p}

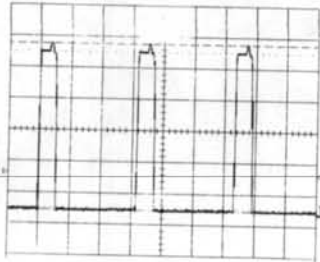

(4) 5.3V_{p,p}

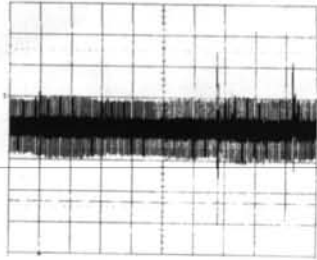

(5) 200mV_{p,p}

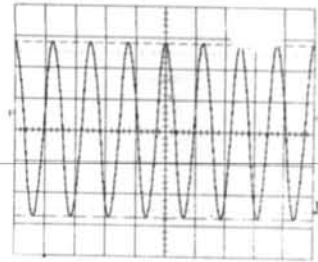

(6) 5.5V_{p,p}

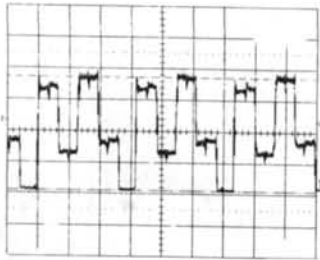

(7) 3.6V_{p,p}

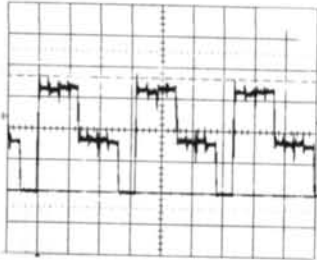

(8) 3.7V_{p,p}

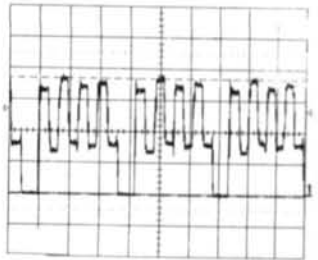

(9) 3.7V_{p,p}

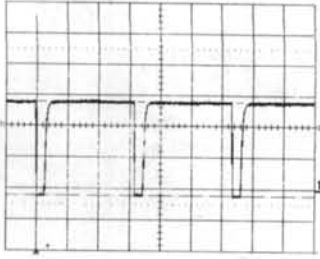

(10) 6V_{p,p}

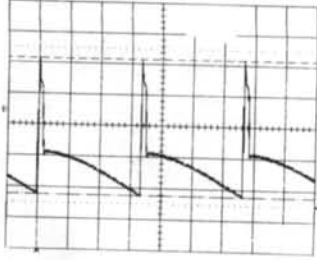

(11) 44V_{p,p}



(12) 862V_{p,p}

(13) 1.6V_{p,p}(L)

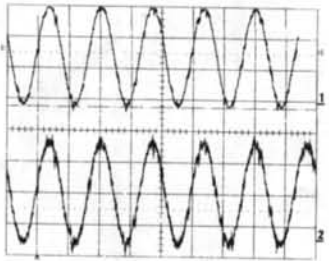

(13) 1.86V_{p,p}(R)

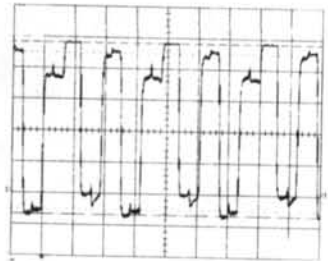
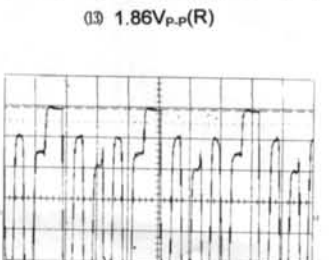

(15) 110V_{p,p}

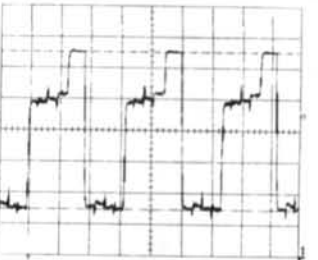

(16) 101V_{p,p}

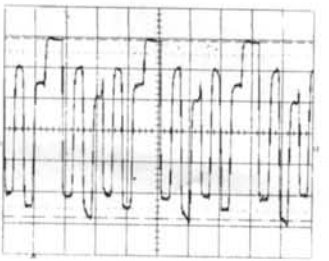

(17) 114V_{p,p}

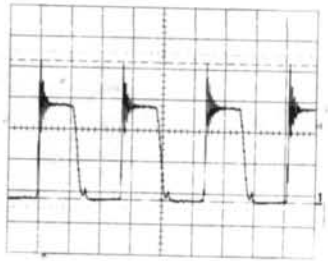

(18) 444V_{p,p}

WARNING: BEFORE SERVICING THIS CHASSIS, READ THE “X-RAY RADIATION PERCAUTION”, “SAFETY PRECAUTION” AND “RPRODUCT SAFETY NOTICE” ON PAGE 1&2 OF THIS MANUAL.

CAUTION: 1. The shaded areas makes in the schematic diagram and the parts list designate components which have special characteristics important for safety and should be replaced only with type identical to those in the original circuit or specified in the parts list. Before replacing any of these components, read carefully the PRODUCT SAFETY NOTICE on page 2.

2. Do not degrade the safety of the receiver through improper servicing.

ELECTRICAL PARTS LIST

MAIN BOARD

SYMBOL	PART NO.	DESCRIPTION	QUANTITY
	782-K2035-010	MAIN PCB	
CRYSTAL			
G801	329-58001-00	8MHZ	1
DIODE			
VD534	340-00291-00	TEU2YX	1
VD562	340-00005-00	S5295J	1
VD342,341,532,533	340-00288-00	TFR155	4
VD530	340-00292-00	TRU3A	1
VD204,504506,502	340-00001-003	N4148	5
VD601,602,509	340-00001-003	1N4148	3
VD321,501	340-00005-003	S5295J	2
VD301	340-00086-003	TVR-1B	1
VD343	340-00288-003	TFR155	1
REGULATED DIODE			
VD803	340-50380-003	HZ4B1	1
VD302,531,346	340-50510-003	HZ5C2	3
VD507	340-50950-003	HZ9C3	1
VD503	340-51560-003	HZ16-1	1
VD561	340-51850-003	HZ18-3	1
VD508	340-50560-003	HZ6B1	1
TRANSISTOR			
V323	343-18030-80	ST1803DHI	1
V322	343-23830-60	2SC2383-0	1
V101	343-27170-00	2SC2717	1

SYMBOL	PART NO.	DESCRIPTION	QUANTITY
V505,507,324	343-38070-00	2SC3807	3
V508	343-00420-404	SFORIB42	1
V810	343-05620-604	2SA562TM-O	1
V205,501,801,802,V01,509	343-10150-104	2SA1015Y Pr2.5	6
V201,302,502,601,803,206-208	343-18150-104	2SC1815-Y	8
V506	343-18150-204	2SC 1815-BL	1
CERAMIC CAPACITOR			
C348	459-5133K-00	RQC05B331K-H46CA	1
C327	459-8182K-00	DE0707B821K2K	1
C503,504	459-B147M-20	ECK-DNS471MBX !	2
C521	459-B222M-20	ECK-DNS222MEX !	1
C506-509	459-B247R-00	DE0807F472ZAC250V !	4
C511	459-6222R-00	DE0805E222Z1K	1
C522	459-6310R-00	DE1510E103Z1K	1
C530	459-8133K-00	DE0707B331K2K	1
C513	459-8168K-00	DE0707B681K2K	1
C302,V09,V10	459-2010H-102	CC45-CH1H100JYR	3
C804	459-2027H-102	CC1-08C-CH-63V-27PF-J	1
C822,823	459-2047H-102	CC45-CH1H470JYR	2
CV07,V08,V11,V12,240,239	459-2110H-102	CC45-CH1H101JYR	6
C808	459-2118H-102	CC45-CH1H181JYR	1
C203,324,560,821	459-2210K-002	CK45-B1H102KYR	4
C106-109,208-210,215,224,230,236 C238,243,346,535,539,550,557,802, C806,820,825,344,604	459-2310R-002	CK45-F1H103ZYR	23
C542-544,V13,351	459-2410R-002	DD308-63F104Z50	5
C532,536,540,342,347,515	459-5133K-002	RQC05B331K-H46CA	6
C610-613	459-2110H-102	CC45-CH1H101JYR	4
C322	459-5210K-002	CK45-B2H102KYR	1
C332	459-5233K-002	CK45-B2H332KYR	1
THIN-FILM CAPACITOR			
C516	462-00212-H02	CC11-100V-1200P-J	1
C220	462-00282-H0	CL11-100V-8200pF-J	1
C502	462-2B410-M0V	250VAC-0.1uF-M !	1
C501	462-2B422-M0V	250VAC-0.22uF-M !	1
C505	462-25410-K0	CL21-400V-0.1uF-K	1
C331	462-53356-K0	CBB12-200V-0.056uF-K	1
C330	462-53439-H0	CBB12-200V-0.39uF-J	1
C325	462-88247-H0	CBB81-1600V-4700PF-J	1
C326	462-88268-H0	CBB81-1600V-6800pF-J	1
C205	462-B0510-H0	CL21X-50V-1uF-J	1

SYMBOL	PART NO.	DESCRIPTION	QUANTITY
C206	462-B0310-H02	CL21X-50V-0.01uF-J	1
C232,233,308,309	462-B0410-H02	CL21X-50V-0.1uF-J	4
C222	462-B0447-H02	CL21X-50V-0.47uF-J	1
C301,608,609	462-00210-H02	CL11-100V-1000PF-J	3
C810	462-00215-H02	CL11-100V-1500PF-J	1
C213,256	462-00222-H02	CL11-100V-2200PF-J	2
C333	462-00256-H02	CL11-100V-5600PF-J	1
ELECTROLYTIC CAPACITOR			
C549	464-6E547-M0	CD110-25V-4.7uF-M	2
C610	464-6D822-M0	CD110-16V-2200uF-M	1
C541	464-6E822-M0	CD110-25V-2200uF-M	1
C350	464-6F722-M0	CD110-35V-220uF-M	1
C307,341	464-6F810-M0	CD110-35V-1000uF-M	2
C202,221	464-60447-M0	CD110-50V-0.47uF-M	2
C323	464-62510-M0	CD288-160V-1uF-M	1
C329	464-62547-M0	CD288-160V-4.7uF-M	1
C352	464-62633-M0	CD288-160V-33uF-M	1
C349	464-65610-M0	CD288-250V-10uF-M	1
C214	464-6D710-M0	CD110-16V-100uF-M	1
C207,343,548	464-6D747-M0	CD110-16V-470uF-M	3
C534,537,555,556,223	464-6D810-M0	CD110-16V-1000uF-M	5
C531	464-04747-M0R	200USP470MA35	1
C510	464-05722-M0R	CD293-250V-220uF-M	1
C801,805,229,V01,235,602,V04	464-6D610-M0	CD110-16V-10uF-M	7
C209	464-6D710-M0	CD110-16V-100uF-M	1
C551	464-60610-M0	CD110-50V-10uF-M	1
C234,345,603,605,606,547,201,824	464-6D610-M02	CD110-16V-10uF-M	11
CV02,V03,V06,807	464-6D610-M02	CD110-16V-10uF-M	
C244,607,310	464-6D647-M02	CD110-16V-47uF-M	3
CV05,533	464-6D710-M02	CD110-16V-100uF-M	2
C538	464-6D733-M02	CD110-16V-330uF-M	1
C546	464-6E647-M02	CD110-25V-47uF-M	1
C303	464-6F722-M02	CD110-35V-220uF-M	1
C212,228,231	464-60422-M02	CD110-50V-0.22uF-M	3
C211,225-227,809	464-60510-M02	CD110-50V-1uF-M	5
C102,204,306	464-60547-M02	CD110-50V-4.7uF-M	3
C561	464-60610-M02	CD110-50V-10uF-M	1
C105	464-6D747-M02	CD110-16V-470uF-M	1
C514	464-60647-M02	CD110-50V-47uF-M	1
CARBON RESISTOR			
R552	467-1D227-H0	RT14-1/4W-2.7K-J	1

SYMBOL	PART NO.	DESCRIPTION	QUANTITY
R531	467-1D122-H0	RT14-1/4W-220Ω-J	1
R547	467-1D210-H0	RT14-1/4W-1K-J	1
R533	467-1D268-H0	RT14-1/4W-6.8K-J	1
C548	467-1C122-H0	1/6W-220Ω-J	1
R308	467-1C001-H03	1/6W-1Ω -J	1
R107	467-1C033-H03	1/6W-33 Ω -J	1
R807	467-1C047-H03	1/6W-47 Ω -J	1
RV11-V13,V16,V21	467-1C075-H03	1/6W-75 Ω -J	5
R103,109,110,202,223-226,230,231 R256,812,850,851,V02,V03,237,216 R217	467-1C110-H03	1/6W-100 Ω -J	19
R207-209	467-1C115-H03	1/6W-150 Ω -J	3
R210-212	467-1C120-H03	1/6W-200 Ω -J	3
R108,236,860	467-1C122-H03	1/6W-220 Ω -J	3
R106	467-1C127-H03	1/6W-270 Ω -J	1
R241,320,322	467-1C133-H03	1/6W-330 Ω -J	3
R240	467-1C139-H03	1/6W-390 Ω -J	1
R810,856	467-1C147-H03	1/6W-470 Ω -J	2
R814	467-1C168-H03	1/6W-680 Ω -J	1
R204	467-1C182-H03	1/6W-820 Ω -J	1
R105,222,234,235,238,315,801,803 R852,V18,213-215,868	467-1C210-H03	1/6W-1K-J	14
R859	467-1C215-H03	1/6W-1.5K-J	1
R811,V17	467-1C222-H03	1/6W-2.2K-J	2
R101	467-1C362-H03	1/6W-62K-J	1
R229,813	467-1C233-H03	1/6W-3.3K-J	2
R818,819,310	467-1C239-H03	1/6W-3.9K-J	3
R861,541,542	467-1C247-H03	1/6W-4.7K-J	3
R104,V08,V09	467-1C256-H03	1/6W-5.6K-J	3
R221	467-1C282-H03	1/6W-8.2K-J	1
R809,820,822,853,854,866,V01,V04 RV10,V14,V05,220,306,311,602,603 R607,804,808,867,V15,V19,V20,549	467-1C310-H03	1/6W-10K-J	24
R302,609,610,817	467-1C312-H03	1/6W-12K-J	4
R102,309	467-1C315-H03	1/6W-15K-J	2
R314	467-1C318-H03	1/6W-18K-J	1
R232,233,805	467-1C327-H03	1/6W-27K-J	3
R206,246,305,855	467-1C330-H03	1/6W-30K-J	4
R604	467-1C347-H03	1/6W-47K-J	1
R816	467-1C368-H03	1/6W-68K-J	1
R601,V06,V07	467-1C410-H03	1/6W-100K-J	3

SYMBOL	PART NO.	DESCRIPTION	QUANTITY
R205	467-1C422-H03	1/6W-220K-J	1
R201	467-1C433-H03	1/6W-330K-J	1
R228	467-1C439-H03	1/6W-390K-J	1
R815	467-1C456-H03	1/6W-560K-J	1
R203	467-1C515-H03	1/6W-1.5M-J	1
R511	467-1D010-H03	RT14-1/4W-10 Ω -J	1
R512	467-1D047-H03	RT14-1/4W-47 Ω -J	1
R325,506	467-1D210-H03	RT14-1/4W-1K-J	2
R510	467-1D218-H03	RT14-1/4W-1.8K-J	1
C811	462-00218-H02	CL11-100V-1800PF-J	1
R505	467-1D256-H03	RT14-1/4W-5.6K-J	1
R554	467-1D310-H03	RT14-1/4W-10K-J	1
R553	467-1D330-H03	RT14-1/4W-30K-J	1
INDUCTANCE WITH COLOUR CODES			
L204	471-2010K-00	SPT0305-100K-5	1
L102	471-2B56K-00	SPT0305-R56K-5	1
L103	471-2B68K-00	SPT0305-R68K-5	1
L802	471-2012K-00	SPT0305-120K-5	1
L601,V01-V06	471-2210K-10	LGA0410-1000uH-K	7
L801,201-203,208,209	471-2012K-003	SPT0305-120K-5	6
L101	471-2068K-003	SPT0305-680K-5	1
LV07	471-2110K-003	SPT0305-101K-5	1
PASTE CAPACITOR			
C826,827	456-3110H-13	1206CG101J500BA	2
IC			
N505	352-05740-00	uPC574	1
N502	352-06210-60	TLP621-GB	1
N801	352-24080-50	M24C08BN6	1
NV01	352-40520-60	TC4052BP	1
N501	352-56530-00	STR-G5653	1
N601	352-75220-00	AN7522N	1
N303	352-78009-10	TA78L009AP	1
N301	352-81720-10	TDA8172	1
RECTIFIER			
DB501	340-80022-00	T2SB60	1
S TERMINAL			
XV05	364-91202-00	CKX5-2K-2	1
AV SOCKET			
XV01	364-98205-00	AV901-6	1
RELAY			
RL501	457-12019-90	JQX-14FF-012-1HS !	1

SYMBOL	PART NO.	DESCRIPTION	QUANTITY
SAW FILTER			
Z201	458-07008-00	M1962M	1
METAL RESISTOR			
R508	467-2GB15-H0	2W-0.15 Ω -JL	1
R307	467-2E120-H0	1/2W-200 Ω -JL	1
R227	467-2E127-H0	1/2W-270 Ω -JL	1
R507	467-2E168-H0	1/2W-680 Ω -JL	1
R342	467-2F210-H0	1W-1K Ω -JL	1
R313	467-2E268-H0	1/2W-6.8k Ω -JL	1
R532	467-2FA47-H0	1W-4.7 Ω -JL	1
R546	467-2F175-H0	1W-750 Ω -JL	1
R326,327	467-2F210-H0	1W-1K Ω -JL	2
R323	467-2F220-H0	1W-2K Ω -JL	1
R328	467-2F310-H0	1W-10k Ω -JL	1
R504	467-2F422-H0	1W-220K-JL	1
R345	467-2G012-H0	2W-12 Ω -JL	1
R530,545	467-2G315-H0	2W-15k Ω -JL	2
MELTABLE RESISTOR			
R538	467-4FB47-H0	1W-0.47 Ω -JL	1
R536,537	467-4E001-H0	1/2W-1 Ω -JL	2
R350,351	467-4FB33-H0	1W-0.33 Ω -JL	2
R555	467-4F001-H0	1W-1 Ω -JL	1
R343	467-4F010-H0	1W-10 Ω -JL	1
CEMENT RESISTOR			
R324	467-50233-H8	RY27-3H-5W-3.3K-J !	1
WIRE-ROUND RESISTOR			
R303	467-6FA12-H0	RX21-1-1.2 Ω -J	1
CARBON RESISTOR			
R503	467-8E510-H0A	1/2W-1M Ω -J !	1
R501	467-8E522-H0A	1/2W-2.2M-J !	1
R518	467-8E556-H0A	1/2W-5.6M Ω -J !	1
POTENTIOMETER			
RP501	468-01108-00	GVA061-100 Ω ±20%	1
THERMISTOR			
RT501	469-10023-00	96708 (9 Ω)	1
R502	469-40004-00	5D2-14LC	1
SWITCH TRANSFORMER			
T503	470-00279-00	SR4038A !	1
H-DRIVE TRANSFORMER			
T301	472-10038-00	DE1939	1

SYMBOL	PART NO.	DESCRIPTION	QUANTITY
CERAMIC FILTER			
Z203	475-15451-00	LT4.5MB	1
Z202	475-25451-00	XT4.5MB	1
H-LINEARITY COIL			
L333	477-00065-00	HL1830H-X13	1
POWER FILTER			
T501,502	477-20028-00	LF21065	2
ADJUSTABLE INDUCTANCE			
L322	477-30026-00	TLN2130	1
FIXED INDUCTANCE			
L501	477-40031-00	LGB-75uH-M	1
L502	477-40164-00	LGB1012-L100	1
FBT			
T302	472-24204-00	BSC24-3031!	1
OTHER			
DEGAUSSING COIL	477-12105-00	DX-56-2	1
CRT	335-2122L-00	A51QDX992X002(H)	1
POWER CORD	491-702D0-02	UL	1
FU501(FUSE)	569-16101-90	5TT2.5A/250V	1
A101 (TUNER)	590-40707-00	115-B-8035AZ	1

ELECTRICAL PARTS LIST FOR CRT PCB

SYMBOL	PART NO.	DESCRIPTION	QUANTITY
	782-K2035-020	CRT PCB	
DIODE			
VD401-403	340-00001-00	1N4148	3
TRANSISTOR			
V401-403	343-26880-60	2SC2688M	3
V404	343-18150-10	2SC1815-Y	1
CRT SOCKET			
X403	364-58210-00	GZS10-2-102G !	1
CERAMIC CAPACITOR			
C406	459-2310R-00	CT1-08-2F4-63V-103Z	1
C401,402	459-2139H-90	CC1-10-SL-63V-391J	2
C403	459-2147H-90	CC1-12-SL-63V-471J	1
C407	459-8222K-00	DE1005B222K2K	1
ELECTROLYTIC CAPACITOR			
C411	464-6D710-M0	CD110-16V-100uF-M	1

SYMBOL	PART NO.	DESCRIPTION	QUANTITY
C409	464-65610-M0	CD288-250V-10uF-M	1
INDUCTANCE WITH COLOUR CODES			
L401	471-1110K-00	EL0606SKI-101K	1
CARBON RESISTOR			
R401-403	467-1C110-H0	1/6W-100 Ω -J	3
R410-412	467-1C133-H0	1/6W-330 Ω -J	3
R404-406	467-1C130-H0	1/6W-300 Ω -J	3
R407-409	467-1C247-H0	1/6W-4.7K-J	3
R422	467-1C322-H0	1/6W-22K-J	1
R413-415	467-1E212-H0	1/2W-1.2K-J	3
R423	467-1C218-H0	1/6W-1.8K-J	1
METAL RESISTOR			
R419-421	467-2G315-H0	2W-15k Ω -JL	3
MELTABLE RESISTOR			
R426	467-4FA27-H0	1W-2.7 Ω -JL	1
INDUCTANCE WITH COLOUR CODES			
L402	471-2068K-10	LGA0410-68uH-K	1

ELECTRICAL PARTS LIST FOR KEYBOARD PCB

SYMBOL	PART NO.	DESCRIPTION	QUANTITY
	782-K2035-0500	KEYBOARD PCB	
CARBON RESISTOR			
R907	467-1C412-H0	1/6W-120K-J	1
R904	467-1C312-H0	1/6W-12K-J	1
R901	467-1C218-H0	1/6W-1.8K-J	1
R908	467-1C047-H0	1/6W-47 Ω -J	1
R905	467-1C318-H0	1/6W-18K-J	1
R906	467-1C330-H0	1/6W-30K-J	1
R903	467-1C256-H0	1/6W-5.6K-J	1
R902	467-1C247-H0	1/6W-4.7K-J	1
ELECTROLYTIC CAPACITOR			
C901	464-6D710-M0	CD110-16V-100uF-M	1
LIGHT-EMITTING DIODE			
LEDG	340-10021-50	2EF565 (GREEN)	1
LDER	340-10039-20	HFR205 (RED)	1
IC			
RC901	352-00380-00	HS0038	1
CERAMIC CAPACITOR			
C902	459-2410R-00	DD308-63F104Z50	1

ELECTRICAL PARTS LIST FOR SIDE AV PCB

SYMBOL	PART NO.	DESCRIPTION	QUANTITY
	782-K2035-2900	SIDE AV PCB	
ELECTROLYTIC CAPACITOR			
CV15,CV16	464-6D610-M0	CD110-16V-10uF-M	1
CARBON RESISTOR			
RV22•RV23	467-1D115-H0	RT14-1/4W-150 Ω -J	1

ELECTRICAL PARTS LIST FOR MTS PCB

SYMBOL	PART NO.	DESCRIPTION	QUANTITY
	782-Q2735-310	MTS PCB	
TRANSISTOR			
VS01,S02	343-18150-10	2SC1815-Y	2
ELECTROLYTIC CAPACITOR			
CS19	464-6D710-M0	CD110-16V-100uF-M	1
CS01	464-60610-M0	CD110-50V-10uF-M	1
CS02,S09	464-60433-M0	CD110-50V-0.33uF-M	2
CS03	464-60533-M0	CD110-50V-3.3uF-M	1
CS14	464-6E547-M0	CD110-25V-4.7uF-M	1
CS08,S15-S18,S20	464-60522-M0	CD110-50V-2.2uF-M	6
CERAMIC CAPACITOR			
CS12	459-5210K-00	RQC07B102K-H46CA	1
CS04,S06,S10,S21	459-2410R-00	DD308-63F104Z50	4
THIN-FILM CAPACITOR			
CS05	462-B0322-H0	CL21X-50V-0.022uF-J	1
CS07	462-B0333-H0	CL21X-50V-0.033uF-J	1
CS11	462-B0422-H0	CL21X-50V-0.22uF-J	1
CARBON RESISTOR			
RS01	467-1C233-H0	1/6W-3.3K-J	1
RS02	467-1C418-H0	1/6W-180K-J	1
RS03,S08	467-1C210-H0	1/6W-1K-J	2
RS04,S09	467-1C120-H0	1/6W-200 Ω -J	2
RS05,S10	467-1C168-H0	1/6W-680 Ω -J	2
RS06,S07	467-1C110-H0	1/6W-100 Ω -J	2
INDUCTANCE WITH COLOUR CODES			
LS01	471-2068K-10	LGA0410-68uH-K	1
IC			
NS01	352-58320-50	AN5832SA	1

EXPLODED VIEW

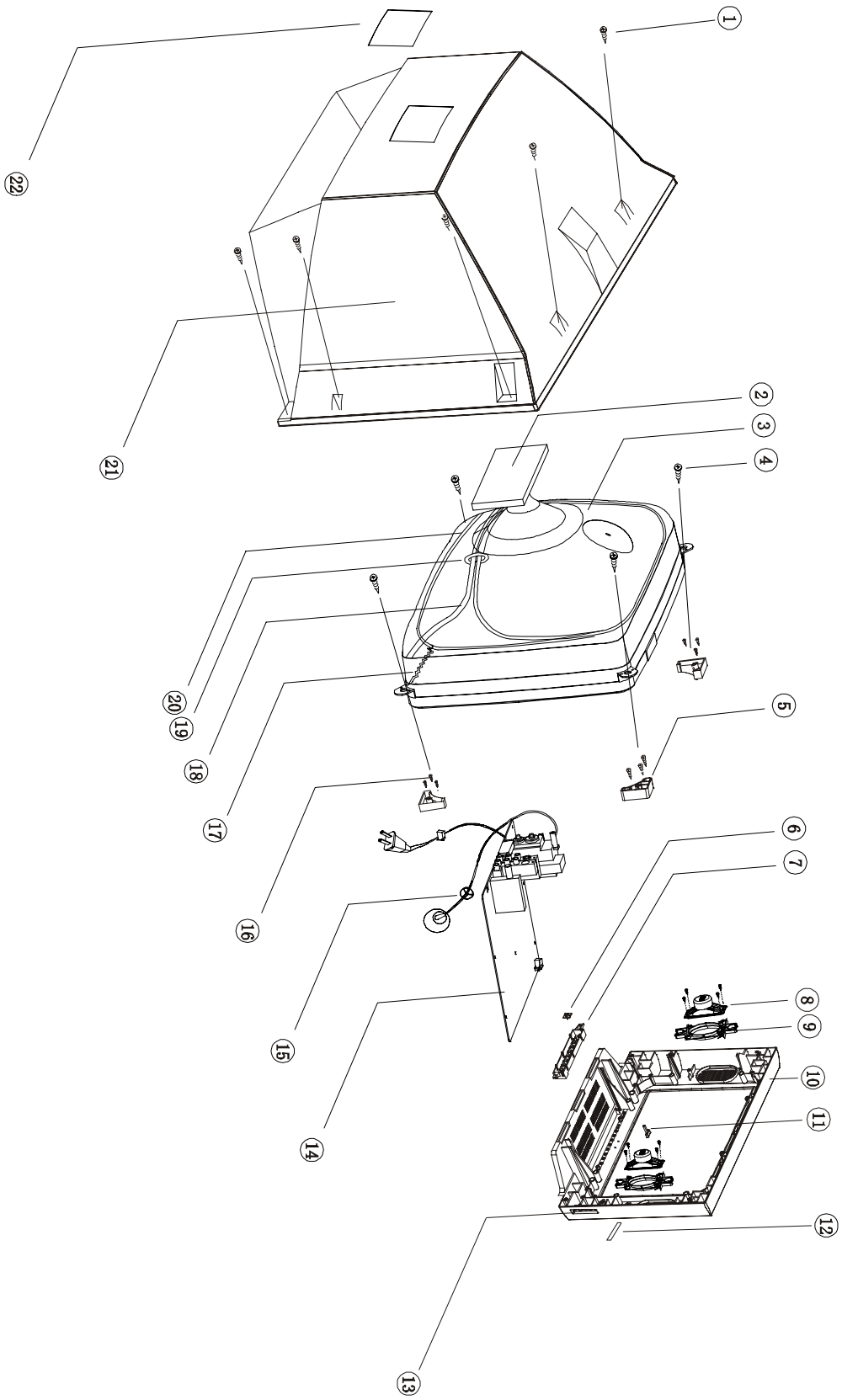

PARTS LIST OF EXPLODED VIEW

NO.	NAME	PART NO.	NO.	NAME	PART NO.
1	SCREW	851-24012-14	16	SCREW	851-53012-14
2	CRT BOARD	667-K2035-02	17	BRAIDED PULLING SPRING	838-10012-00
3	CRT	335-21227-00U	18	DEGAUSSING COIL	477-12105-00U
4	SCREW	851-53008-11	19	THREAD CLASP	742-30032-00
5	CRT FIXER	868-20314-00A	20	BRAIDED PULLING	123-K20350-01
6	LED COLUMN	700-60145-00	21	BACK CABINET	780-10871-J02
7	BUTTON	360-10001-00	22	LABEL	880-10205-095
8	SPEAKER	384-40908-B0	23		
9	SPEAKER BRACKET	870-20700-00A	24		
10	FRONT CABINET	780-1C855J0E1	25		
11	POWER BUTTON	877-50405-02	26		
12	LOGO	880-10392-01			
13	SIDE AV	667-K2035-29			
14	MAIN BOARD ASSEMBLY	667-K2035-01			
15	POWER THREAD CLASP	887-20044-01			